

# **User Manual**

## **Online UPS**

### **Uninterruptible Power Supply System**

**1. INTRODUCTION.**

- 1.1. GRATEFULNESS LETTER.
- 1.2. USING THIS MANUAL.
  - 1.2.1. USED SYMBOLS AND CONVENTIONS.
  - 1.2.2. FOR MORE INFORMATION AND/OR HELP.
  - 1.2.3. SAFETY AND FIRST AID.

**2. QUALITY AND STANDARD GUARANTEE.**

- 2.1. MANAGEMENT DECLARATION.
- 2.2. STANDARD.
- 2.3. ENVIRONMENT.

**3. PRESENTATION.**

- 3.1. VIEWS.
  - 3.1.1. VIEWS OF THE EQUIPMENT.
  - 3.1.2. CORRESPONDING LEGENDS TO THE EQUIPMENT VIEWS.
- 3.2. STRUCTURE.
  - 3.2.1. STRUCTURAL SCHEME.
- 3.3. OPERATING PRINCIPLE.
  - 3.3.1. NORMAL OPERATION, (⇒).
  - 3.3.2. OPERATION WITH MAINS FAILURE, (→).
  - 3.3.3. OPERATION WITH INVERTER NOT ACTIVE, (⇒).
  - 3.3.4. OPERATION IN MANUAL BYPASS, (⇒).

**4. INSTALLATION.**

- 4.1. IMPORTANT SAFETY INSTRUCTIONS.
  - 4.1.1. BATTERIES SAFETY INSTRUCTIONS.
  - 4.1.2. TO GET INTO ACCOUNT.
- 4.2. EQUIPMENT RECEPTION.
  - 4.2.1. UNPACKING AND CONTENT CHECKING.
  - 4.2.2. STORAGE.
  - 4.2.3. TRANSPORT TO LOCATION.
  - 4.2.4. LOCATION.
- 4.3. CONNECTION.
  - 4.3.1. TO THE MAINS CONNECTION, TERMINALS (X1 TO X4).
  - 4.3.2. INDEPENDENT STATIC BYPASS LINE CONNECTION, TERMINALS (X14 TO X17). ONLY IN VERSIONS UPS-B.
  - 4.3.3. CONNECTION OF THE OUTPUT, TERMINALS (X6 TO X9).
  - 4.3.4. UPS CONNECTION TO EACH BATTERY PACK IN CABINET, TERMINALS (X11, X12 AND X23) AND (X47, X48 AND X49).
  - 4.3.5. CONNECTION MAIN PROTECTIVE EARTHING TERMINAL (⚡) AND PROTECTIVE EARTH BONDING TERMINAL (⚡).
  - 4.3.6. COM PORT TO RELAY. CONNECTOR (X32).
  - 4.3.7. PORT COM RS-232 & RS-485. CONNECTOR (X32).
  - 4.3.8. EPO TERMINALS (X50).

**5. OPERATION.**

- 5.1. START UP.
  - 5.1.1. CONTROL BEFORE START UP.
  - 5.1.2. START UP PROCEDURE.
- 5.2. COMPLETE UPS SHUTDOWN.
- 5.3. EMERGENCY POWER OFF (EPO) OPERATION.
- 5.4. BYPASS MANUAL SWITCH (MAINTENANCE).
  - 5.4.1. PRINCIPLE OF OPERATION.
  - 5.4.2. TRANSFER TO MAINTENANCE BYPASS.
  - 5.4.3. TRANSFER TO NORMAL OPERATION.

**6. CONTROL PANEL AND DISPLAY DESCRIPTION.**

- 6.1. CONTROL PANEL PARTS.
- 6.2. BASIC FUNCTIONS OF KEYBOARD FROM SYNOPTIC.
  - 6.2.1. MESSAGES MENUS AND CLASSIFICATION IN SUBMENUS.
- 6.3. SCREEN DESCRIPTION.
  - 6.3.1. MAIN LEVEL (SCREEN MENU 0.0). SEE FIG. 30.
  - 6.3.2. "MEASURES" LEVEL (SCREEN MENU 2.0). SEE FIG. 32.
  - 6.3.3. "MEASURES" LEVEL (SCREEN MENU 2.0). SEE FIG. 32.
  - 6.3.4. "PARAMETERS" LEVEL (SCREEN MENU 3.0). SEE FIG. 33.
  - 6.3.5. "ALARMS" LEVEL (SCREEN MENU 4.0). SEE FIG. 34.
  - 6.3.6. "DATA LOGGER" LEVEL (SCREEN MENU 5.0). SEE FIG. 35.
  - 6.3.7. "CONFIGURATION" LEVEL (SCREEN MENU 6.0). SEE FIG. 36.
  - 6.3.8. RATED VALUES SCREENS (SCREEN MENU 7.0). SEE FIG. 37.

**7. MAINTENANCE, WARRANTY AND SERVICE.**

- 7.1. BASIC MAINTENANCE GUIDE.
  - 7.1.1. BATTERY FUSES.
  - 7.1.2. BATTERIES.
  - 7.1.3. FANS.
  - 7.1.4. CAPACITORS.
- 7.2. WARRANTY CONDITIONS.
  - 7.2.1. COVERED PRODUCT.
  - 7.2.2. OUT OF THE SCOPE OF SUPPLY.

**8. ANNEXES.**

- 8.1. GENERAL TECHNICAL SPECIFICATIONS.
- 8.2. GLOSSARY.
- 8.3. SAFETY INSTRUCTIONS

## 1. INTRODUCTION.

### 1.1. Gratefulness letter.

We would like to thank you in advance for the trust you have placed in us by purchasing this product. Read this instruction manual carefully before starting up the equipment and keep it for any possible future consult that can arise.

We remain at your entire disposal for any further information or any query you should wish to make.

Yours sincerely.

- ❑ The equipment here described can cause important physical damages due to wrong handling. This is why, the installation, maintenance and/or fixing of the here described equipment must be done by our staff or specifically authorised.
- ❑ According to our policy of constant evolution, we reserve the right to modify the specifications in part or in whole without forewarning.
- ❑ All reproduction or third party concession of this manual is prohibited without the previous written authorization of our firm.

### 1.2. Using this manual.

The target of this manual is to give explanations and procedures for the installation and operating of the equipment. This manual has to be read carefully before installing and operating it. Keep this manual for future consults.

This equipment has to be **installed by qualified staff** and, the simple help of this manual, **it can be usable by personnel without specific training**.

### 1.2.1. Used symbols and conventions



«Warning» symbol. Carefully read the indicated paragraph and take the stated prevention measures.



«Danger of electrical discharge» symbol. Pay special attention to it, both in the indication on the equipment and in the paragraph referred to in this user's manual.



«Main protective earthing terminal» symbol. Connect the earth cable coming from the installation to this terminal.



«Earth bonding terminal». Connect the earth cable coming from the installation to this terminal.



«Notes of information» symbol. Additional topics that complement the basic procedures.



**Preservation of the environment:** The presence of this symbol in the product or in their associated documentation states that, when its useful life is expired, it will not be disposed together with the domestic

residuals. In order to avoid possible damages to the environment, separate this product from other residuals and recycle it suitably. The users can contact with their provider or with the pertinent local authorities to be informed on how and where they can take the product to be recycled and/or disposed correctly.

### 1.2.2. For more information and/or help.

For more information and/or help of the version of your specific unit, request it to our Service and Technical Support (**S.T.S.**).

### 1.2.3. Safety and first aid.

Together with the equipment and this «User and installation manual», it is provided the information regarding to «Safety instructions». Before proceeding to the installation or commissioning, check that **both information** are available; otherwise request them. It is obligatory the compliance of the «Safety instructions», being the user the legal responsible regarding to its observance. Once read, keep them for future consults that can arise.

## 2. QUALITY AND STANDARD GUARANTEE.

### 2.1. Management declaration.

Our target is the client's satisfaction, therefore this Management has decided to establish a Quality and Environmental policy, by means of installation a Quality and Environmental Management System that becomes us capable to comply the requirements demanded by the standard **ISO 9001:2000** and **ISO 14001:2004** and by our Clients and concerned parts too.

Likewise, the enterprise Management is committed with the development and improvement of the Quality and Environmental Management System, through:

- The communication to all the company about the importance of satisfaction both in the client's requirements and in the legal and regulations.
- The Quality and Environmental Policy diffusion and the fixation of the Quality and Environment targets.
- To carry out revisions by the Management.
- To provide the needed resources.

### Management agent.

The Management has designated as management agent the person in charge about the Quality and Environment department, who with independence of other responsibilities, has the responsibility and authority to assure that the processes of the quality and environmental management system are established and maintained; to inform to the Management about the operating of the quality and environmental management system, including the necessities for the improvement; and to promote the knowledge of the client's requirements and environmental requirements at all the levels of the organization.

In the next PROCESS MAP is represented the interaction among all the processes of the Quality and Environmental System:

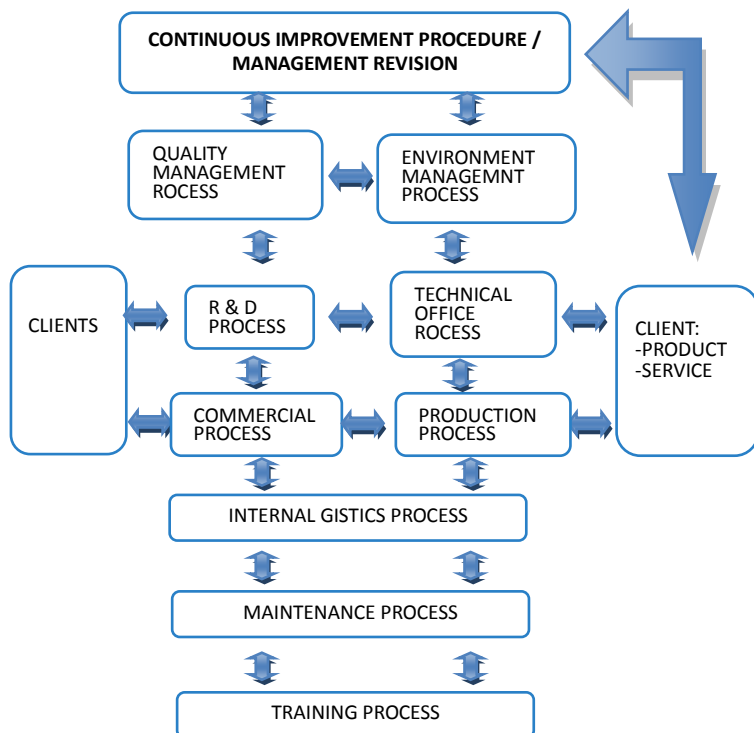

**Fig.1.** Process map of Quality and environmental system.

### 2.2. Standard.

The UPS series product is designed, manufactured and commercialized in accordance with the standard **EN ISO 9001** of Quality Management Systems. The **CE** marking shows the conformity to the EEC Directive (quoted between brackets) by means of the application of the following standards

- **2006/95/EC** Low voltage directive.
- **2004/108/EC** Electromagnetic Compatibility directive (EMC)  
In accordance with the specifications of the harmonized standards:
  - **EN-IEC 62040-1.** Uninterruptible power supply (UPS). Part 1-1: General and safety requirements for UPS's used in accessible areas by end users.
  - **EN-IEC 60950-1.** IT equipments. Safety. Part 1: General requirements.
  - **EN-IEC 62040-2.** Uninterruptible power supply (UPS). Part 2: Prescriptions for Electromagnetic compatibility (EMC).
  - **EN-IEC 62040-3.** Uninterruptible power supply (UPS). Part 3: Methods of operation specification and test requirements.

The manufacturers responsibility is excluded in the event of any modification or intervention in the product by the customer's side.

### 2.3. Environment.

This product has been designed to respect the environment and has been manufactured in accordance with the standard ISO 14001.

#### Equipment recycling at the end of its useful life:

Our company commits to use the services of authorised societies and according to the regulations, in order to treat the recovered product at the end of its useful life (contact your distributor).

**Packing:** To recycle the packing, follow the legal regulations in force.

**Batteries:** The batteries mean a serious danger for health and environment. The disposal of them must be done in accordance with the standards in force.

### 3. PRESENTATION.

#### 3.1. VIEWS.

##### 3.1.1. Views of the equipment.

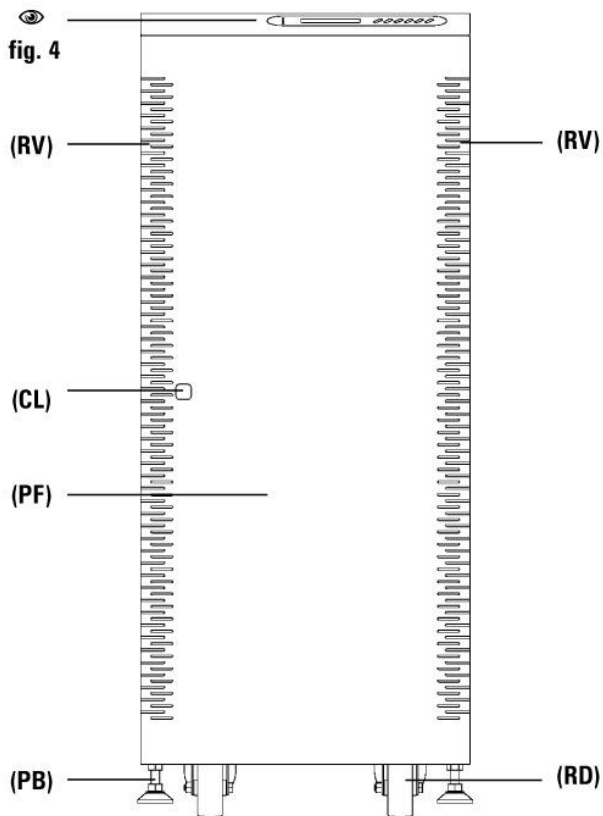

**Fig2.** Cabinet front view for UPS up to 10kVA with front door closed.

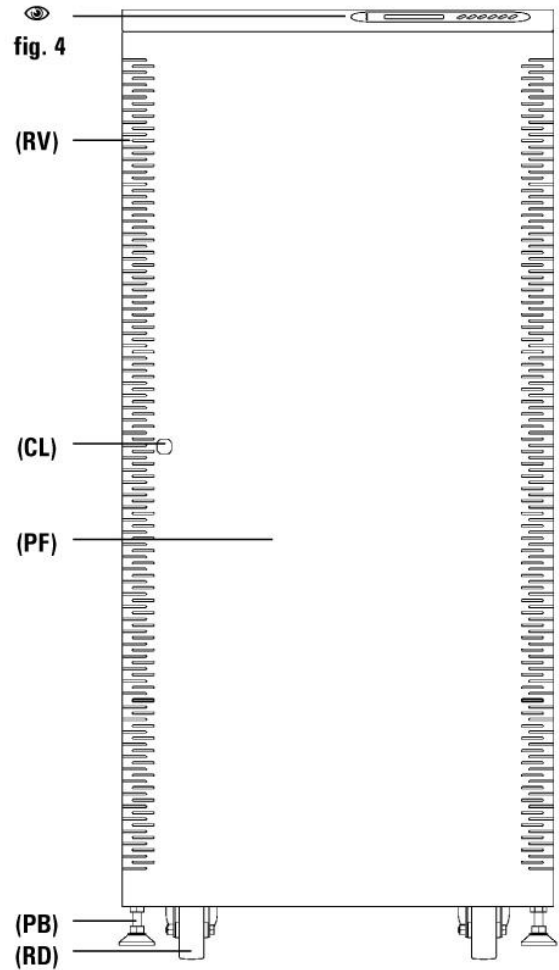

**Fig.3.** Cabinet front view for UPS from 15 to 40kVA with front door closed.

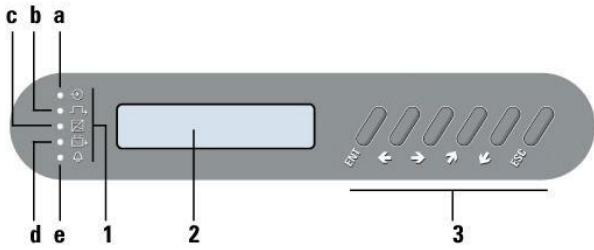
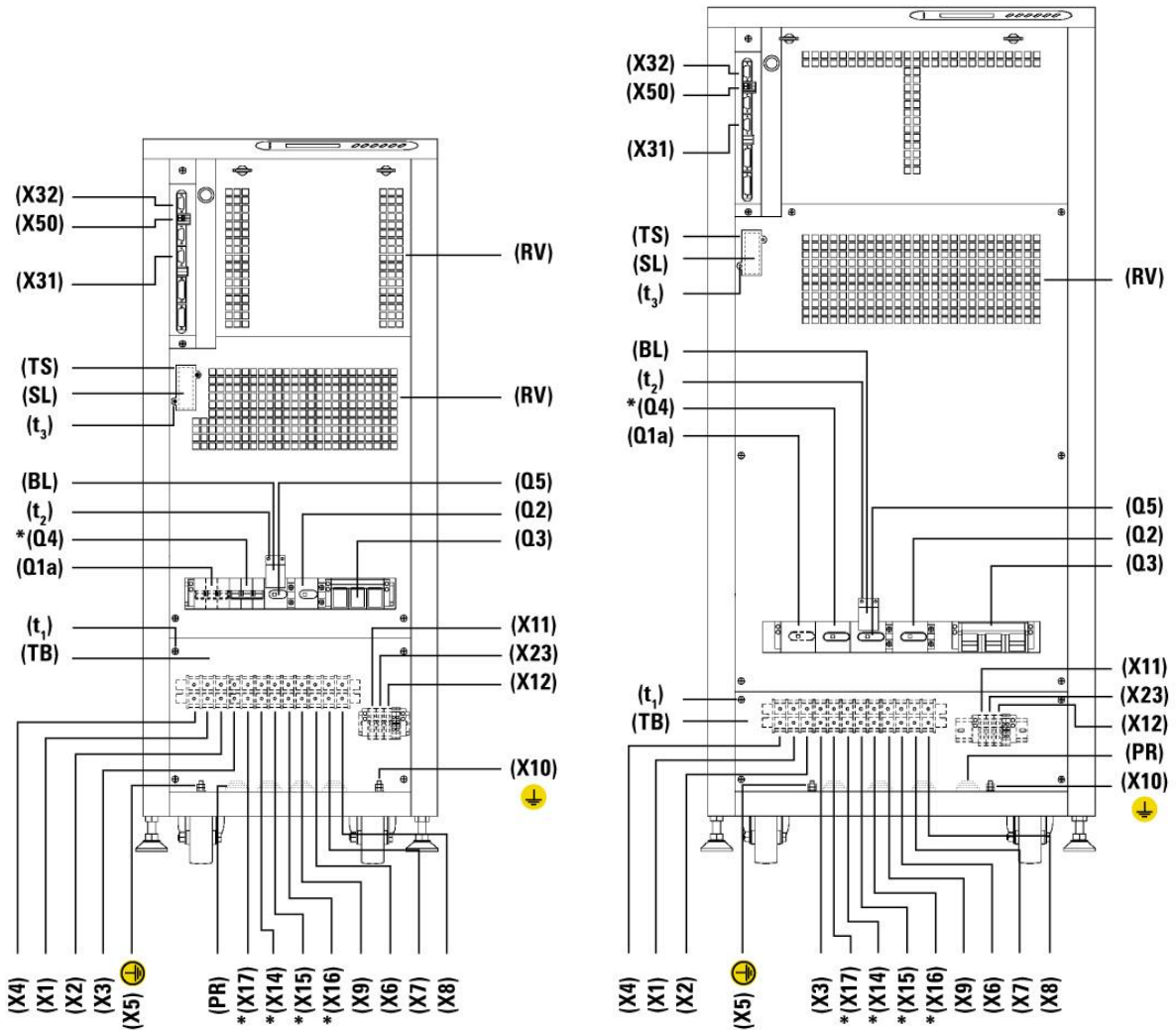

Fig.4. Control panel view.



**\*Only in optional version UPS-B (Static Bypass line independent).**

Fig.5. Cabinet front view for UPS up to 10kVA with front door opened and configuration of three phase input / three phase output.

Fig.6. Cabinet front view for UPS up to 15 to 40kVA with front door opened and configuration of three phase input three phase output.

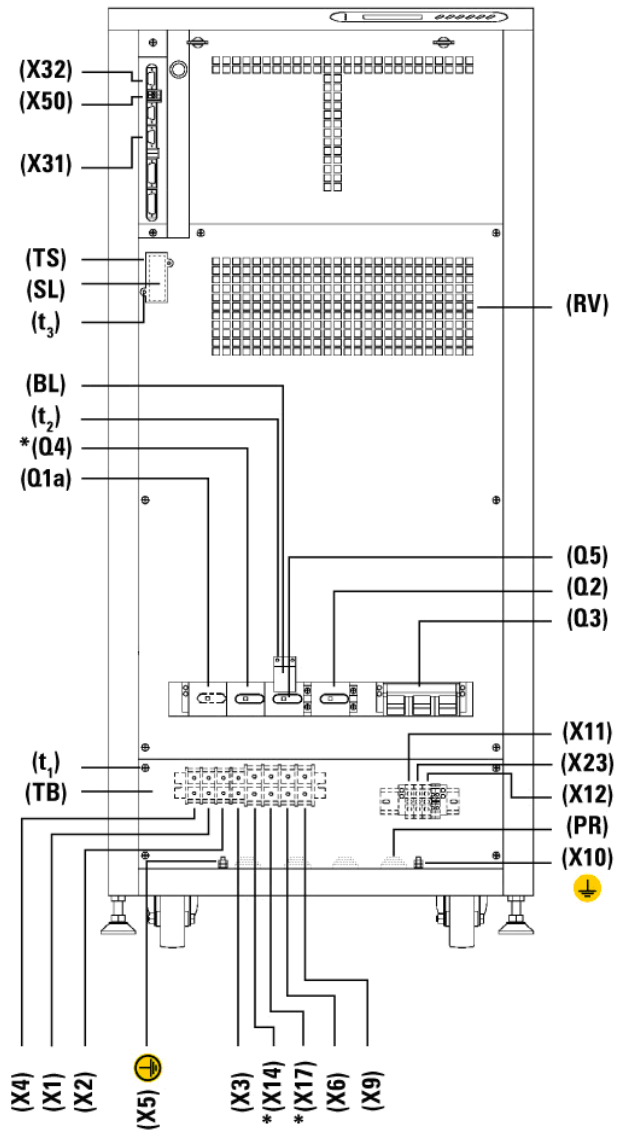
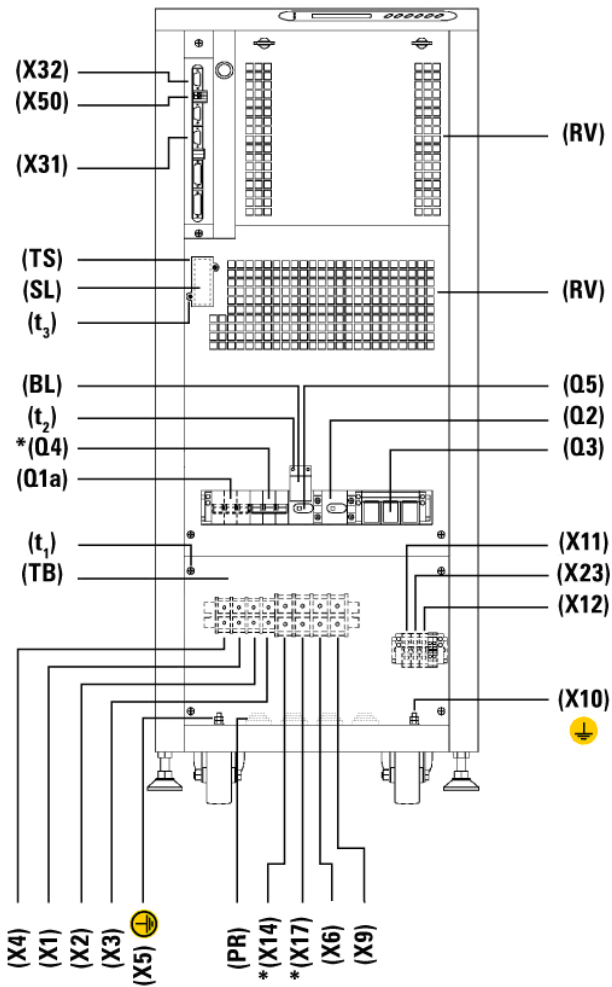

**\*Only in optional version UPS-B (Static Bypass line independent).**

**Fig.7.** Cabinet front view for UPS up to 10kVA with front door opened and configuration of three phase input / single phase output.

**Fig.8.** Cabinet front view for UPS from 15 to 40kVA with front door opened and configuration of three phase input / single phase output.

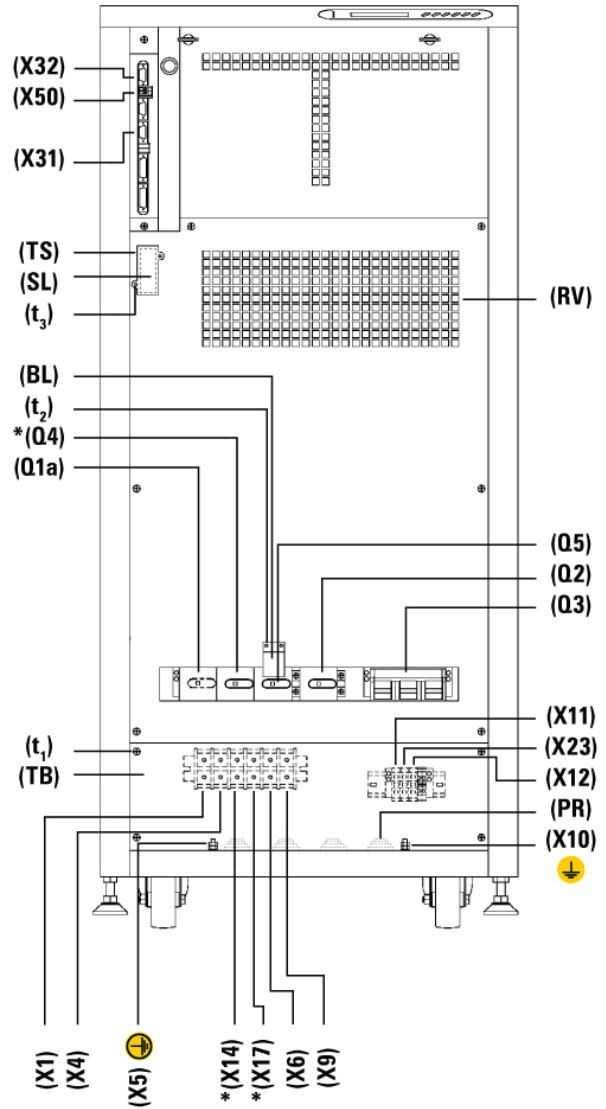
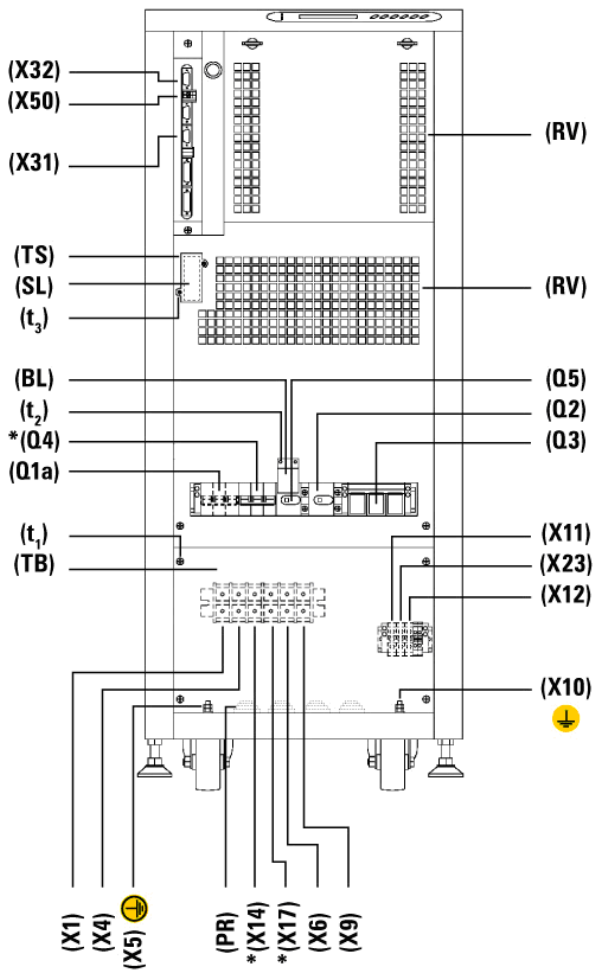

**\*Only in optional version UPS-B (Static Bypass line independent).**

**Fig.9.** Cabinet front view for UPS up to **10kVA** with front door opened and configuration of single phase input / single phase output.

**Fig.10.** Cabinet front view for UPS from **15 to 40kVA** with front door opened and configuration of single phase input / single phase output.



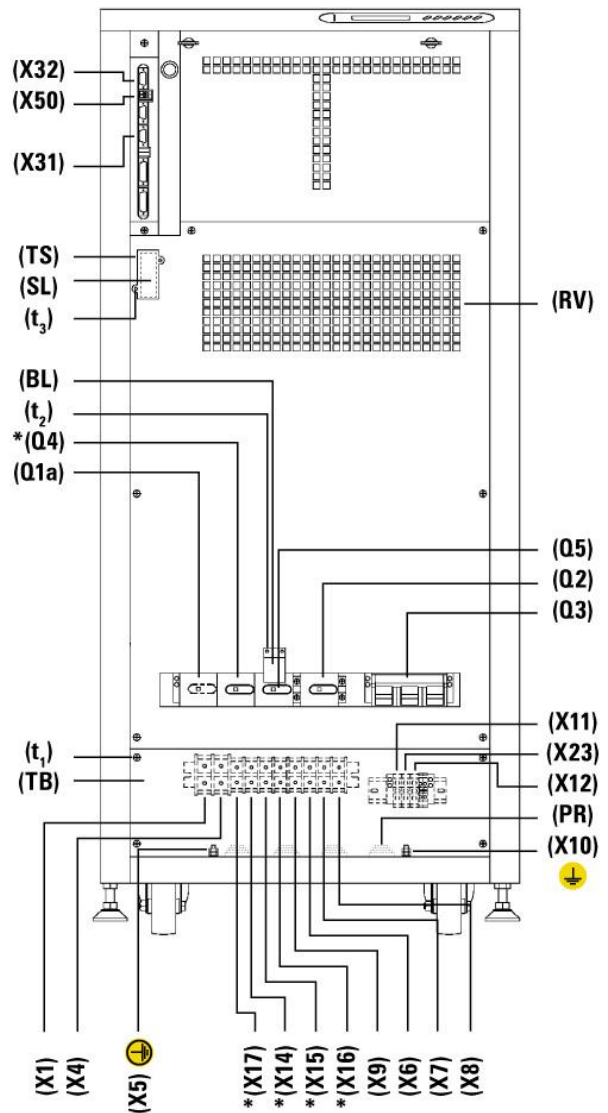
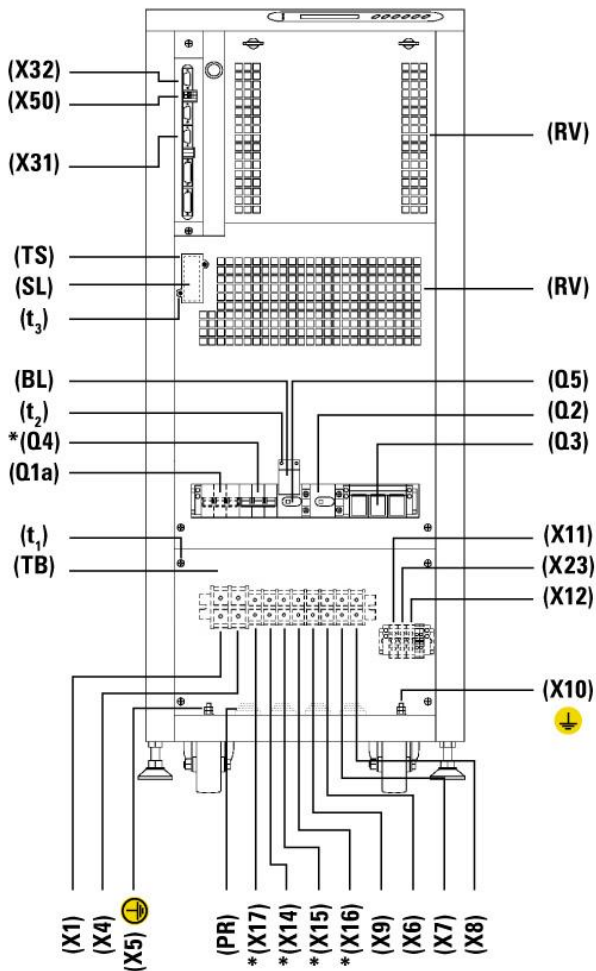

**\*Only in optional version UPS-B (Static Bypass line independent).**

**Fig.11.** Cabinet front view for UPS up to 10kVA with front door opened and configuration of single phase input / three phase output.

**Fig.12.** Cabinet front view for UPS from 15 to 40kVA with front door opened and configuration of single phase input / three phase output.

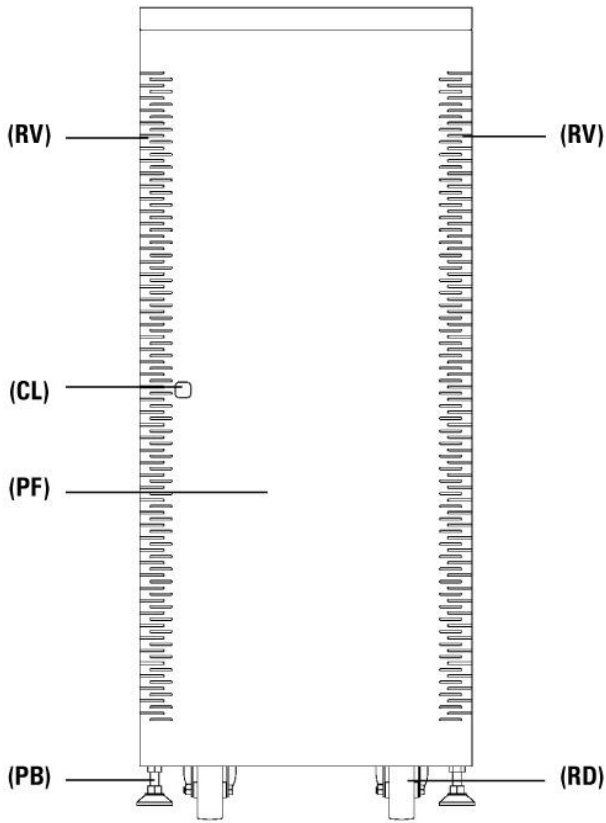

**Fig.13.** No 1 battery cabinet front view with front door closed.

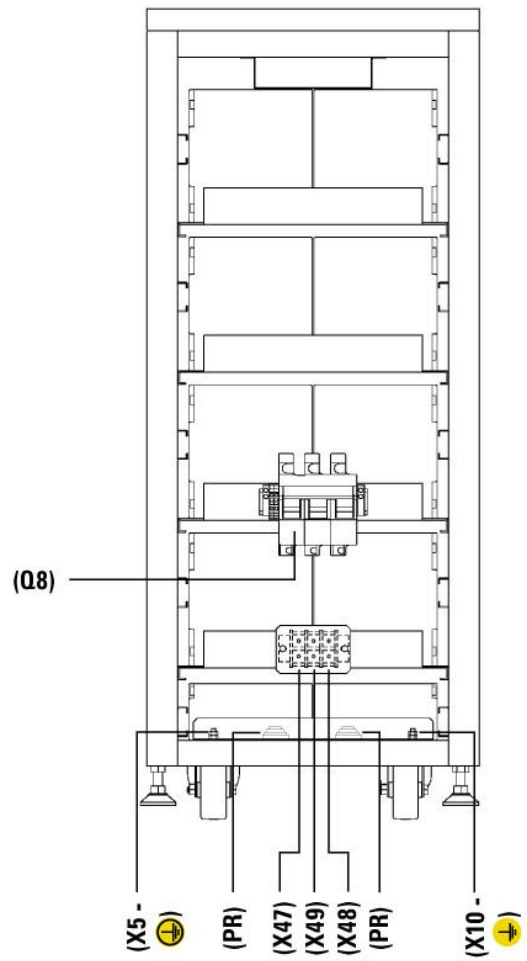

**Fig.14.** No 1 battery cabinet front view with front door opened.

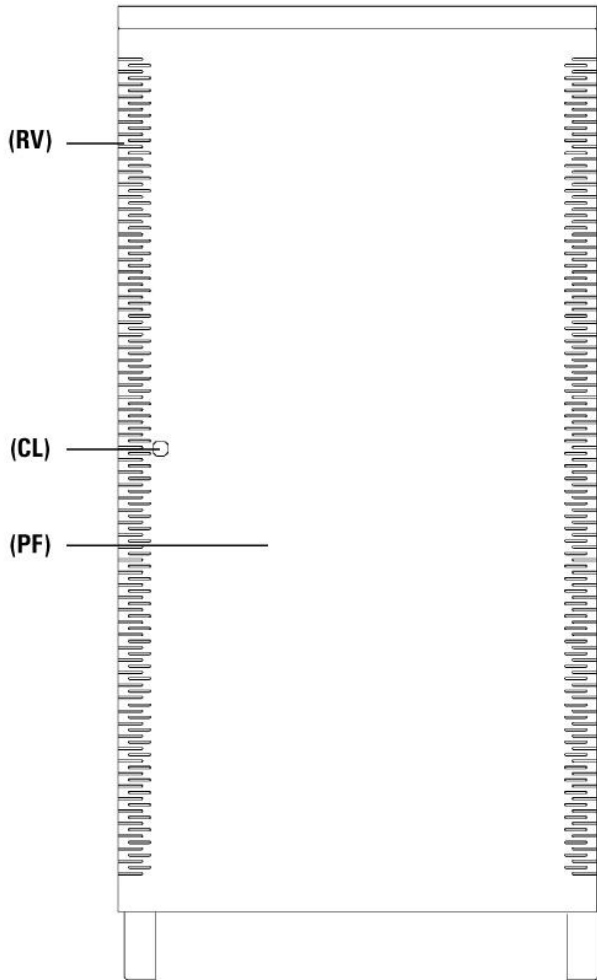

**Fig.15.** No 2 battery cabinet front view with front door closed.

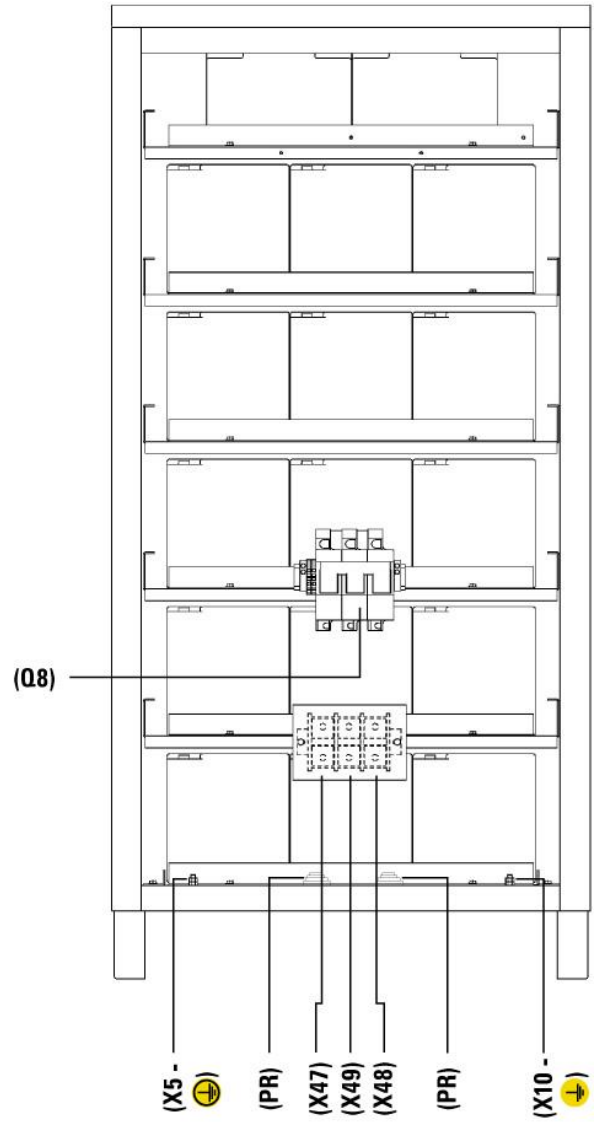

**Fig.16.** No 2 battery cabinet front view with front door opened

### 3.1.2 Corresponding legends to the equipment views.

#### **Protection and handling elements (Q\*):**

- (Q1a)** Input circuit breaker or switch according to power of the equipment.
- (Q2)** Output switch.
- (Q3)** Battery fuse holder switch with 3 fuses (models up to 40 kVA) or switch (for higher models).
- (Q4)** Static bypass (Only in optional version -B).
- (Q5)** Maintenance bypass switch.
- (Q8)** Battery fuse holder switch 3 fuses, located in the battery cabinet.

#### **Connecting elements (X\*):**

- (X1)** Phase input terminal R.
- (X2)** Phase input terminal S.
- (X3)** Phase input terminal T.
- (X4)** Neutral input terminal N.
- (X5)** Main protection earthing terminal (⚡).
- (X6)** Phase output terminal U.
- (X7)** Phase output terminal V.
- (X8)** Phase output terminal W.
- (X9)** Neutral output terminal N.
- (X10)** Earth bonding terminal for load or loads and/or battery cabinet (⚡).
- (X11)** Batteries terminal + (Only for external battery model).
- (X12)** Batteries terminal – (Only for external battery model).
  
- (X14)** Phase static bypass terminal R (Only in optional version -B).
- (X15)** Phase static bypass terminal S (Only in optional version -B).
- (X16)** Phase static bypass terminal T (Only in optional version -B).
- (X17)** Neutral static bypass terminal N (Only in optional version -B).
- (X23)** Batteries terminal N (middle tap, Only for external battery model).
- (X31)** DB9 connector COM RS-232 and RS-485 ports.
- (X32)** DB9 connector relay interface.
- (X47)** Batteries terminal + of external batteries cabinet.
- (X48)** Batteries terminal – of external batteries cabinet.
- (X49)** Batteries terminal N (middle tap) of external batteries cabinet.
- (X50)** Terminals for external EPO.

#### **Keyboard and optical indications control panel (PC):**

- (LCD)** Display LCD.
- (ENT)** Key «ENTER».
- (ESC)** Key «ESC».
- (↶)** Key move up.
- (↷)** Key move down.
- (→)** Key move to right.
- (←)** Key move to left.
- (a)** Rectifier Input Voltage OK led (green).
- (b)** Output voltage unit from the Bypass led (orange).
- (c)** Inverter is working led (green).
- (d)** Unit working from batteries -mains failure- led (red).
- (e)** General alarm. In case of any alarm of the unit led (red).

#### **Other abbreviations:**

- (BL)** Mechanical block for manual bypass switch **(Q5)**.
- (CL)** Lock for cabinet front door.
- (PB)** Levelers and immobilising elements.
- (PC)** Control panel.
- (PF)** Cabinet front door.
- (PR)** Cable stuffers or wire cones.
- (RD)** Scroll wheel.
- (RV)** Ventilation grille.
- (SL)** Slot for optional intelligent card.
- (TB)** Terminal cover.
- (TS)** Slot cover **(SL)**.
- (t<sub>1</sub>)** Screws fixing for terminals cover **(TB)**.
- (t<sub>2</sub>)** Screws fixing for mechanical block **(BL)** for switch **(Q5)**.
- (t<sub>3</sub>)** Screws fixing for slot cover **(TS)**.

### 3.2. Definition and structure.

#### 3.2.1. Structural Scheme.

In single line diagrams of figures 17 and 18 show, as an example, the basic structure of a standard equipment and another one with separate bypass line, for a three phase input and output configuration. For any other configuration, the quantity of cables and terminals at the input, output and bypass will only vary; internal structure of the equipment will never do it.

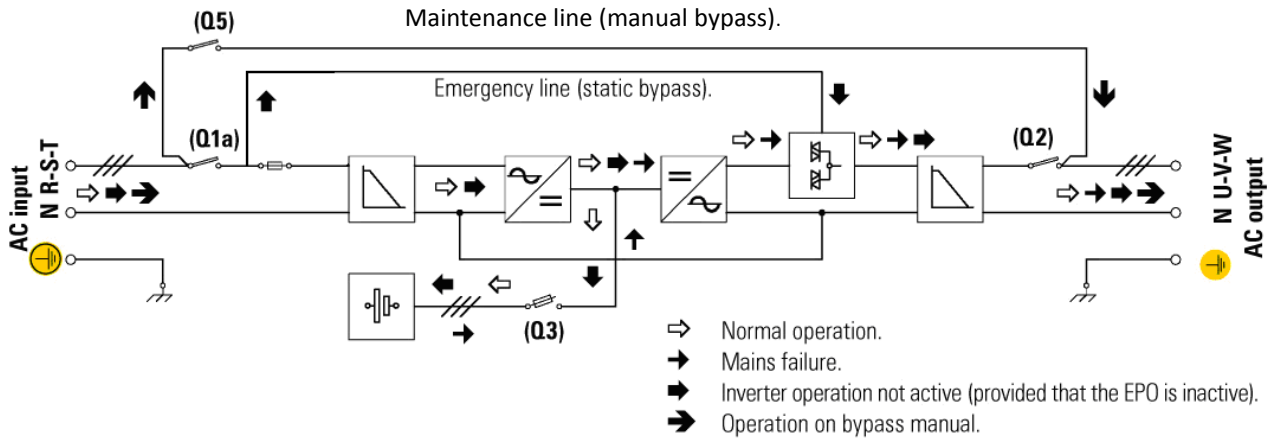
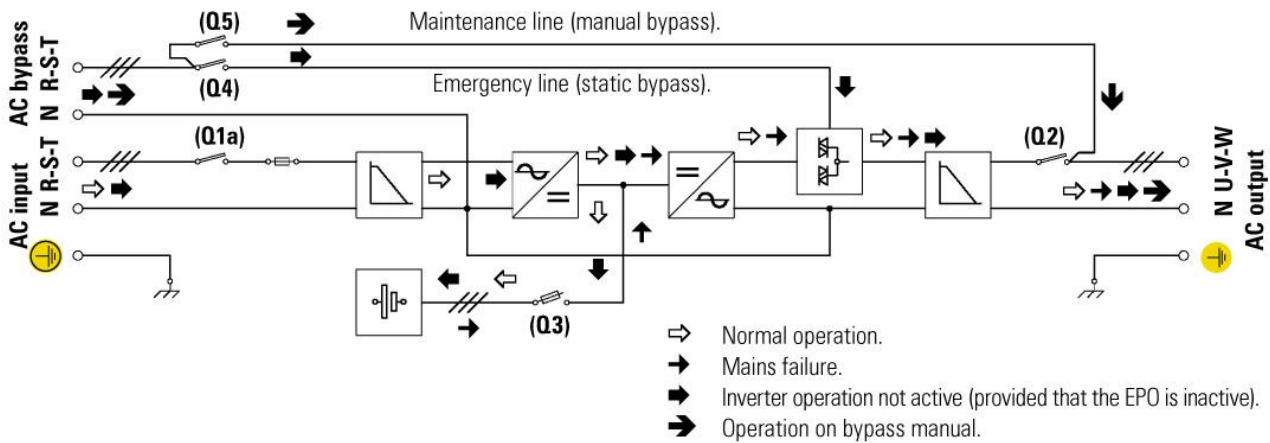

Fig.17. UPS block diagram with operating flows.



**⚠** In equipments with separate bypass line, an isolation transformer must be placed at any of both input power supply mains of the UPS (rectifier input or static bypass), in order to avoid the direct connection of the neutral of both mains through the internal wiring of the equipment.

This is only applicable power supply comes from two different electrical mains, as for example:

- Two different electrical companies.
- One electrical company and a generator set, ...

Fig.18. UPS-B block diagram with operating flows.

### 3.3. Operating principle.

This online UPS is a double conversion system AC/DC, DC/AC with a sine wave output that gives safe protection in extreme conditions of power supply (variations in voltage, frequency, electrical noises, blackout and micro cuts, etc...). Whatever the kind of load that has to be protected, these devices are prepared to assure quality and continuity in the electrical supply.

- The operation is basically as follows:
  - ❑ Rectifier, an IGBT three phase rectifier, converts the AC voltage into DC by absorbing a pure sinewave current (THD <2%), and charging batteries at constant current / voltage.
  - ❑ The batteries supply the power needed by the inverter in the event of mains failure.
  - ❑ The Inverter deals with transforming the voltage of the DC bus into AC by providing a sine-wave, alternating output stabilised in voltage and frequency suitable for supplying the loads connected on the output.
  - ❑ The basic double conversion structure is complemented by two new functional blocks, the static bypass commutator switch and the manual bypass commutator switch.
  - ❑ The static bypass commutator switch connects the output load directly to the bypass network in special circumstances such as overloading or overheating and reconnects it to the Inverter when normal conditions are restored.
  - ❑ The **UPS-B** version has separate lines for the Inverter and bypass blocks, thus increasing the safety of the installation, as it allows the use of a second mains (generator unit, other company, etc...).
  - ❑ The manual bypass commutator switch isolates the UPS from the mains and from the loads connected on the output, so that maintenance operations may be performed in the UPS without any need to interrupt the supply to the loads.

#### 3.3.1. Normal operation, (⇒).

With the mains present, the rectifier transforms the AC input voltage into DC raising the DC voltage to a suitable level for supplying the inverter and to charge the batteries.

The inverter deals with transforming the voltage of the DC bus into AC, providing a sine wave alternating output, stabilised in voltage and frequency to supply the loads connected to the output (figures 17 and 18).

#### 3.3.2. Operation with mains failure, (→).

In the event of mains failure or should a micro cut occur, the group of batteries supplies the power needed to supply the inverter.

The inverter continues working normally without appreciating the lack of mains and the back-up time of the device depends only on the capacity of the group of batteries (figures 17 and 18).

When the battery voltage reaches end of back-up time, the control blocks the output as protection against a deep battery discharge.

When the mains returns and following the first seconds of analysis, the UPS operates once more as in section «Normal operation».

#### 3.3.3. Operation with inverter not active, (⇒).

The inverter is inactive due to the existence of alarm conditions such as overloads, overheating, end of back-up time, etc... In that cases the rectifier continues charging the batteries to maintain their optimal charge state.

The inverter is also inactive if the unit has not been started up with the keyboard. In that case, the rectifier will be inactive.

In all these cases the output voltage of the UPS is supplied by the emergency bypass line through the static bypass commutator switch (figures 17 and 18), provided that the EPO is inactive

#### 3.3.4. Operation in manual bypass, (⇒).

When we wish to perform some maintenance check on the device, it may be disconnected from the mains without any need to cut the power supply to the system and affect the critical load. The UPS may be intervened, only by technical or maintenance personnel, by means of the maintenance bypass (following specific instructions for that purpose).

## 4. Installation

- Check the Safety Instructions.
- Make sure that the data on the characteristics plate are those required for the installation.
- Any incorrect connection or handling may cause damage to the UPS and/or the loads connected to it. Read these instructions carefully and follow the steps indicated in the established order.
- In the description in this manual, reference is made to terminal connections and the use of switches that are only available in the UPS-B version or devices with extended back-up times. Omit all references to these if your device does not have them.
- This UPS must be installed by qualified staff and it usable by personal with non-specific preparation, just with the help of this «Manual».

### 4.1. Important safety instructions.

- ⚠ As this is a device with class I protection against electric shocks, it is essential to install a protective earth conductor (connect earth (☺)). Connect the conductor to the terminal (X5), before connecting the power supply to the UPS input.
- All connections in the device, including those for control (interface, remote control, ...), will be performed with the switches at rest and without any mains present (UPS power line cut off «Off»).
- It must never be forgotten that the UPS is a generator of electrical power, So users must take all necessary precautions against direct or indirect contact.
- Warning labels should be placed on all primary power switches installed in places away from the device to alert the electrical maintenance personnel of the presence of a UPS in the circuit. The label will bear the following or an equivalent text:

#### **Before working on this circuit.**

- Isolate Uninterruptible Power System (UPS).
- Then check for Hazardous Voltage between all terminals including the protective earth.

#### **⚠ Risk of Voltage Backfeed**

- Once the power supply is powered up to the input of the UPS with static bypass included or with an independent static bypass line, although the inverter is «Off» (shut-down), it doesn't mean no output voltage at the output terminals.  
To do it, it is needed to switch (Q1a), (Q4) and (Q2) to position «Off». It is possible that the UPS might be supplying output voltage from the manual bypass, so this must be considered for the purpose of safety. If the output power supply of the UPS has to be interrupted in this situation, deactivate the switch (Q5).
- In devices with battery terminals, precautions must be taken as they are not isolated from the alternating input line, and there might be dangerous voltage between the battery terminals and the ground.

### 4.1.1. Batteries safety instructions.

- The manipulation and connection of the batteries shall be done and supervised by personnel with battery knowledge.
- For units requested without batteries, the acquisition, installation and connection of the batteries will always be done by the customer and **under his responsibility**. The relative data to the batteries as far as number, capacity and voltage are indicated in the battery label pasted beside the nameplate of the equipment, **respect these data strictly**, the battery polarity connection and the circuit diagram provided with this documentation.
- The battery supply can involve the risk of electric shock and can produce high short circuit current. Observe the following preventive measures before manipulating any terminal block identified in the labelling as «Battery»:
  - ❑ Disconnect the corresponding protection elements.
  - ❑ When connecting a battery cabinet to the equipment, respect the cable's polarity and colour (red-positive; black-negative) indicated in the manual and in the corresponding labelling.
  - ❑ Wear rubber gloves and shoes.
  - ❑ Use tools with insulated handles.
  - ❑ Removes watches, rings or other metal objects.
  - ❑ Do not place metal tools or objects on the batteries.
  - ❑ Never manipulate with your hands or through conducting objects, do not short the battery terminal block or the battery enclosure.
- Never short the battery terminals as it involves a high risk. It involves the detriment of the equipment and batteries.
- Avoid mechanical efforts and impacts.
- Do not open or mutilate the battery. Released electrolyte is harmful to the skin and eyes.
- Do not dispose of batteries in a fire. The batteries may explode.
- In case of contact of the acid with parts of the body, wash immediately with plenty water and call urgently the nearest medical service.
- Batteries involve a serious risk for the health and for the environment.  
Their disposal should be done according to the existing laws.

### 4.1.2. To get into account.

- All the UPS units and the battery packs have terminals as power connection parts, and DB9 connector for the communication channel, located in the inside of the equipment. Follow the steps described next to have access to them:
  - ❑ Unlock the lock (CL) with the special given key.
  - ❑ Rotate it 45° to clockwise and open the frontal door (PF) completely. DB9 connectors from communication ports and terminals for remote EPO button will be uncovered.
  - ❑ Remove the screws (t1), which are fixing the terminal cover (TB) inside of the cabinet and move it away; the power terminals will be uncovered.

Model.	Equipment power (kVA)	Maximum input and bypass current, and nominal output current (A)								
		110 V			120 V			130V		
		Input	Output	Bypass	Input	Output	Bypass	Input	Output	Bypass
UPS-7.5	7.5	66	69	-	60	63	-	56	58	
UPS-10	10	90	90	-	84	84	-	76	76	
UPS-15	15	132	132	-	120	123	-	112	112	
UPS-20	20	177	177	-	159	165	-	150	150	
UPS-30	30	287	287	-	240	246	-	243	243	
UPS-40	40	357	357	-	323	331	-	302	302	
UPS-7.5-B	7.5	66	69	69	60	63	63	56	58	58
UPS-10-B	10	90	90	90	84	84	84	76	76	76
UPS-15-B	15	132	135	135	120	123	123	112	114	114
UPS-20-B	20	177	183	183	159	165	165	150	155	155
UPS-30-B	30	267	273	273	240	246	246	226	231	231
UPS-40-B	40	357	365	365	323	331	331	302	309	309

**Table 1.** Input, output and bypass currents for standard single phase voltage UPS.

Model.	Equipment power (kVA)	Maximum input and bypass current, and nominal output current (A)								
		3x190V			3x208 V			3x225V		
		Input	Output	Bypass	Input	Output	Bypass	Input	Output	Bypass
UPS-7.5	7.5	22	23	-	20	21	-	19	19	
UPS-10	10	30	30	-	28	28	-	25	25	
UPS-15	15	44	45	-	40	41	-	37	38	
UPS-20	20	59	61	-	53	55	-	50	52	
UPS-30	30	89	91	-	80	82	-	75	77	
UPS-40	40	118	122	-	107	110	-	100	103	
UPS-7.5-B	7.5	22	23	23	20	21	21	19	19	19
UPS-10-B	10	30	30	30	28	28	28	25	25	25
UPS-15-B	15	44	45	45	40	41	41	37	38	38
UPS-20-B	20	59	61	61	53	55	55	50	52	52
UPS-30-B	30	89	91	91	80	82	82	75	77	77
UPS-40-B	40	118	122	122	107	110	110	100	103	103

**Table 2** Input, output and bypass currents for standard three phase voltage UPS.



□ Once the connection of the UPS is concluded, place back the cover (TB) and close the door (PF) through the lock (CL).

- The cable cross section of the bypass, input and output lines shall be determined from the maximum currents for the two first and from nominal ones for the output, by respecting the local and/or country Low Voltage Electro-technical standards. To calculate the cross cable sections, take the figures of the current that are stated in tables 1 or 2 depending on the model, single or three phase configuration and nominal voltage value of the UPS. In the nameplate of the equipment are only printed the nominal currents as it is stated in the safety standard EN-IEC 62040-1.
- The protections in the distribution board, they will be of the following characteristics:
  - For the lines input and bypass, type B earth leakage breakers and circuit breakers curve C.
  - For the output (alimentation loads), circuit breaker curve C.

About the size of themselves, they will be, as minimum, with the currents stated in tables 1 and 2 depending on the model, single or three phase configuration and nominal voltage value of the UPS.

- In case were added input, output or bypass peripherals to the UPS like transformers or autotransformers, currents stated in the own nameplates of the of those elements have to be taken into account, in order to use the suitable cross sections, by respecting the Local and/or National Low Voltage Electro-technical Regulations.
- When an equipment has a galvanic isolation transformer, as standard, as an option or installed by the end user, either at the input of UPS, at the bypass line, at the output or in all locations, they have to be fitted in with protections against indirect contacts (earth leakage breaker) at the output of each transformer, because its own feature of isolation will impede the tripping of protections installed at the primary winding of the transformer in case there were an electrical shock in the secondary winding (output of isolation transformer).
- We remind you that all isolation transformers supplied or installed from factory have the neutral cable connected to the ground through a cable bridge between the neutral and ground terminals . If you require an isolated output neutral, please remove this bridge, taking the stated cautions in the respective local and/or national low voltage standards.
- The cable stuffers or wall passages supplied fitted to the metal structure are those recommended to correctly fix the input, output and bypass wires with the sections determined by the National Low Voltage Electro-technical Regulation in accordance with the currents of the device.

If these sections should have to be changed for any reason, this should be done from a separate distribution box and the sections indicated should be maintained from the device to the distribution box.

- In standard equipments up to 30 kVA, batteries are supplied inside the UPS enclosure and for higher power rates, they are supplied in separate cabinet. By default, the UPS has a battery fuse-holder switch (Q3) with 3 fuses for models up to 30 kVA or battery switch (Q3) for models with higher power rate. Regarding battery cabinet, it has a fuse holder switch (Q8) with 3 fuses, for both models with higher power rate of 30 kVA and for extended back up times. In any case, fuses are supplied together with the documentation. Open fuse holder switch (Q3) or (Q8), install the 3 fuses and WAIT TO CLOSE IT until it is indicated.

 **IMPORTANT FOR YOUR SAFETY:** Do not turn the battery fuse holder switch or switch (Q3) located in the equipment or its analogous (Q8) of battery cabinet to "On" (Close), till the equipment is switched on completely, because it can cause irreversible damages to the equipment or accidents.

## 4.2. Equipment Reception.

### 4.2.1. Unpacking and content checking.

- On receiving the device, make sure that it has not suffered any damage in transport. Otherwise, make all pertinent claims to your supplier or to our company. Also check the data in the nameplate, which is stucked inside the front door (PF), corresponds to those specified in the purchase order, to do it, it will be necessary to unpack it. If this is not so, the disconformity must be sent at the earliest, quoting the device manufacturing number and the references of the delivery remittance.
- When the device has been accepted, it is best to pack the UPS once more until it is put into service in order to protect it from any possible mechanical knocks, dust, dirt, etc....
- The packaging of the device consists of a wooden palette, a cardboard or wooden surround depending on the case, expanded polystyrene corner pieces, polyethylene sleeve and band, all recyclable materials; they should therefore be disposed of according to current regulations. We recommend that the packaging should be kept in case its use is necessary in the future.
- To unpack, cut the bands on the cardboard surround and to remove it by above as if outside a cover or remove it with the necessary tools if the surround is made of wood; remove the corner pieces and the plastic sleeve. The UPS will be unpacked on the pallet, to lower it suitable mediums must be used with the needed safety mediums that it behaves; the approximate weights of the table 7 and 8 must be considered.

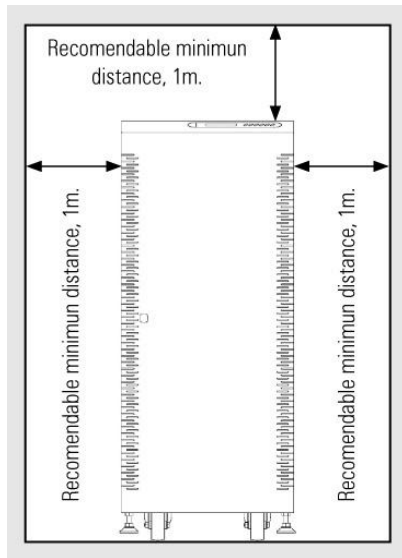

Fig.19. Front view UPS location

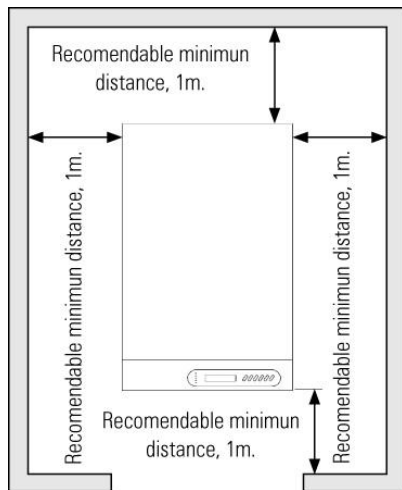

Fig.20. Top view UPS location.

#### 4.2.2. Storage.

- The storage of the equipment will be made in a dry, ventilated place and protected against rain, water jets or chemical agents. It is advisable to maintain the equipment and the battery pack/s, if it is the case, into their original package, which has been designed to assure the maximum protection during the transport and storage.



- In general and other than in special cases, the UPS has hermetically sealed lead-calcium batteries and should not be stored for more than 12 months (see the date the batteries were last charged, noted on the label adhered to the device packaging or on the battery cabinet).
- After this time, connect the device to the mains along with the battery pack/s, as the case may be, start it up according to the instructions described in this manual and charge the batteries for 2 hours from float level.

- Then shutdown the device, disconnect it and keep the UPS and the battery cabinet or cabinets in their original packaging, noting the new battery charge date on each respective label.
- Do not store the unit where the ambient temperature exceeds 40° C or falls below -20° C, as this may degrade the electrical characteristics of the batteries.

#### 4.2.3. Transport to location.

- All UPS have castors to facilitate their transport to their final location. It is important to observe the rough weights indicated in table 7 and 8 both with respect to the site itself and the means to be used to put it there (floor, hoist, lift, stairs, etc...).

#### 4.2.4. Location.

- In the Instructions of Security is indicated that it is necessary to leave a minimum of 25 cm in the contour of the equipment for your ventilation. Nevertheless, one recommends to leave other 75 cm. additional to facilitate the operations of maintenance of the equipment or interventions of the technical service in case of breakdown (see figures 19 and 20).
- The UPS may be put in any place as long as the requirements are fulfilled of the Safety Instruction and the weights are considered that are indicated in table 7 and 8.
- The UPS includes 2 levelling elements (**PB**) located near the front castors, which serve to immobilise the unit once it is in place.
  - Open the frontal door (PF) of the cabinet and proceed as follows:
    - By hand, loosen the levelling elements (**PB**) by turning them anticlockwise until they touch the floor, and then, using a spanner, continue loosening until the castors are raised off the floor by a maximum 0.5 cm, ensuring that it is level.
    - Close the door once more (**PF**).

#### 4.3. Connection.

##### 4.3.1. To the mains connection, terminals (X1 to X4).

- ⚠ As this is a device with class I protection against electric shocks, it is essential to install a protective earth conductor (connect earth (☺)). Connect the conductor to the terminal (**X5**), before connecting the power supply to the UPS input.
- In accordance with safety standard EN-IEC 62040-1, installation has to be provided with a «Backfeed protection» system, as for example a contactor, which will prevent the appearance of voltage or dangerous energy in the input mains during a mains fault (see figure 21 and respect the wiring diagram of «Backfeed protection» depending if the equipment is with single or three phase input)

⚠ There can be no derivation in the line that goes from the «Backfeed protection» to the UPS, as the standard safety would be infringed.

- Warning labels should be placed on all primary power switches installed in places away from the device to alert the electrical maintenance personnel of the presence of a UPS in the circuit.

The label will bear the following or an equivalent text::

**Before working on this circuit.**

- Isolate Uninterruptible Power System (UPS).
- Then check for Hazardous Voltage between all terminals including the protective earth.

⚠ **Risk of Voltage Backfeed.**

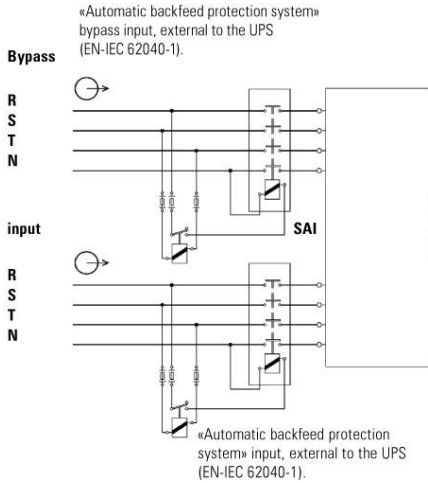

**Three phase input / three phase output configuration.**

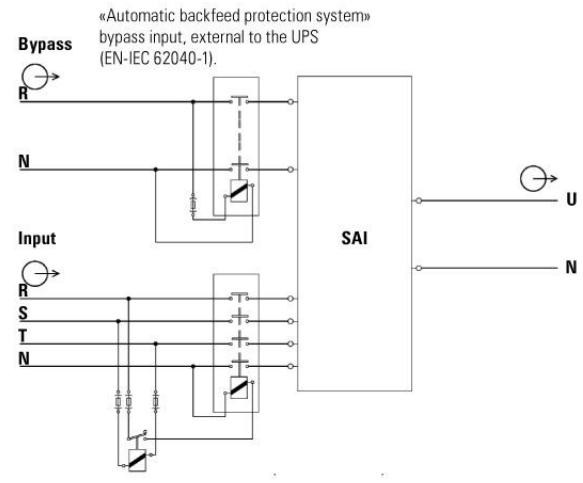

**Three phase input / single phase output configuration.**

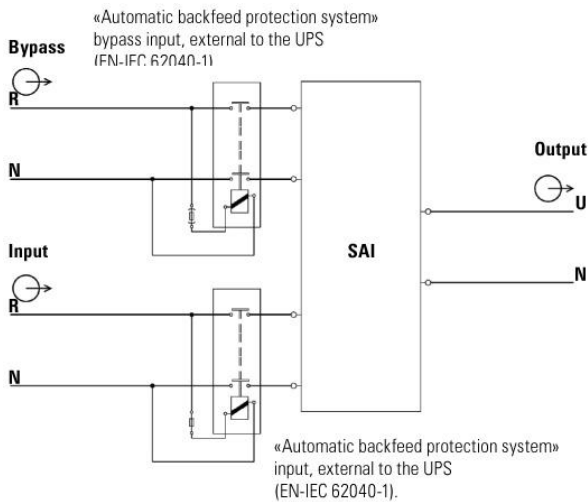

**Single phase input / single phase output configuration.**

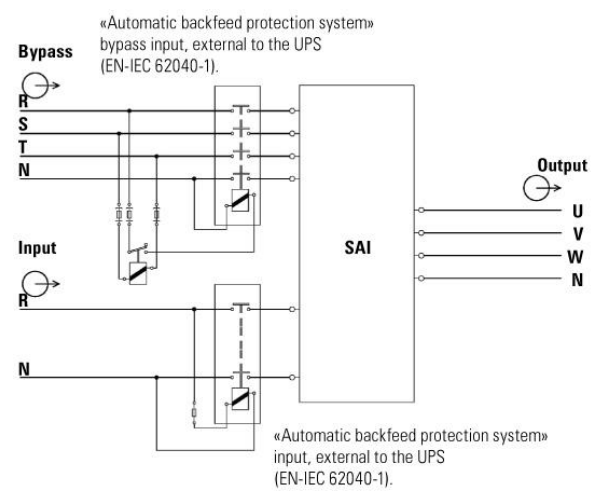

**Single phase input / three phase output configuration.**

**Fig.21.** Block diagram for the «Backfeed protection» application, for the different configurations.

- To connect the cables of mains to the respective terminals according to configuration of the available equipment.

**Connection to the mains three phase :**

Connect the power supply cables N-R-S-T to the input terminals (X4), (X1), (X2) and (X3), respecting the order of neutral and phases indicated on the label of the device and in this manual. If the order of the phases is not respected, the device will not operate.



When there are discrepancies between the labelling and the instructions of this manual, the label will always prevail.

**Connection to the mains single phase :**

Connect the power supply cables R-N to the input terminals (X1) and (X4), respecting the order of phase and neutral indicated on the label of the device and in this manual. If the order of the phases is not respected, the device will not operate.

When there are discrepancies between the labelling and the instructions of this manual, the label will always prevail.

**4.3.2. Independent static bypass line connection, terminals (X14 to X17). Only in versions UPS-B.**

-  As this is a device with class I protection against electric shocks, it is essential to install a protective earth conductor (connect earth (☉)). Connect the conductor to the terminal (X5), before connecting the power supply to the UPS input.
- In accordance with safety standard EN-IEC 62040-1, installation has to be provided with a «Backfeed protection» system, as for example a contactor, which will prevent the appearance of voltage or dangerous energy in the input mains during a mains fault (see figure 21 and respect the wiring diagram of «Backfeed protection» depending if the equipment is with single or three phase input).
-  There can be no derivation in the line that goes from the «Backfeed protection» to the UPS, as the standard safety would be infringed.

- Warning labels should be placed on all primary power switches installed in places away from the device to alert the electrical maintenance personnel of the presence of a UPS in the circuit.

The label will bear the following or an equivalent text:

**Before working on this circuit.**

- Isolate Uninterruptible Power System (UPS).
- Then check for Hazardous Voltage between all terminals including the protective earth.

 **Risk of Voltage Backfeed.**

- To connect the cables of static bypass line to the respective terminals according to configuration of the available equipment.

**Connection to the static bypass line three phase :**

Connect the power supply cables N-R-S-T to the static bypass line terminals (X17), (X14), (X15) and (X16), respecting the order of neutral and phases indicated on

the label of the device and in this manual. If the order of the phases is not respected, the device will not operate. When there are discrepancies between the labelling and the instructions of this manual, the label will always prevail.

**Connection to the static bypass line single phase :**

Connect the power supply cables R-N to the static bypass line terminals (X1) and (X4), respecting the order of phase and neutral indicated on the label of the device and in this manual. If the order of the phases is not respected, the device will not operate.

When there are discrepancies between the labelling and the instructions of this manual, the label will always prevail.

-  In equipments with separate bypass line, an isolation transformer must be placed at any of both input power supply mains of the UPS (rectifier input or static bypass), in order to avoid the direct connection of the neutral of both mains through the internal wiring of the equipment. This is only applicable power supply comes from two different electrical mains, as for example:
  - Two different electrical companies.
  - One electrical company and a generator set, ...

**4.3.3. Connection of the output, terminals (X6 to X9).**

-  As this is a device with class I protection against electric shocks, it is essential to install a protective earth conductor (connect earth (☉)). Connect the conductor to the terminal (X5), before connecting the power supply to the UPS input.
- To connect the cables of output to the respective terminals according to configuration of the available equipment.

**Connection to the output three phase :**

Connect the loads cables N-U-V-W to the output terminals (X9), (X6), (X7) and (X8), respecting the order of neutral and phases indicated on the label of the device and in this manual. If the order of the phases is not respected, the device will not operate.

When there are discrepancies between the labelling and the instructions of this manual, the label will always prevail.

**Connection to the output single phase :**

Connect the loads cables U-N to the output terminals (X6) and (X9), respecting the order of phase and neutral indicated on the label of the device and in this manual. If the order of the phases is not respected, the device will not operate.

When there are discrepancies between the labelling and the instructions of this manual, the label will always prevail.

- With respect to the protection that must be placed on the output of the UPS, we recommend that the output power should be distributed in at least four lines. Each will have a magnetic thermal protection switch of a value of one quarter of the nominal power. This type of power distribution will mean that in the event of a breakdown in any of the machines connected to the device causing a short-circuit, it will affect no more than the line that is faulty. The rest of the connected loads will have their continuity assured due to the triggering of the protection, only the line affected by the short-circuit will remain.

#### 4.3.4. UPS connection to each battery pack in cabinet, terminals (X11, X12 and X23) and (X47, X48 and X49).

- ⚠ As this is a device with class I protection against electric shocks, it is essential to install a protective earth conductor (connect earth (☺)). Connect the conductor to the terminal (X5), before connecting the power supply to the UPS input.
- ⚠ IMPORTANT FOR YOUR SAFETY: Do not turn the battery fuse holder switch or switch (Q3) located in the equipment or its analogous (Q8) of battery cabinet to "On" (Close), till the equipment is switched on completely, because it can cause irreversible damages to the equipment or accidents because the fitter is exposed to ELECTRICAL DISCHARGE DANGERS when connecting the UPS with the battery cabinet.
- UPS connection with battery pack will be done with the supplied cable trunk, by connecting one side to terminals (X11), (X23) and (X12) of UPS and the other one to terminals (X47), (X49) and (X48) of battery pack, always respecting the stated polarity in the labelling of each part and this manual, and the colour of the cables (red for positive, black for negative, blue for middle tap (N) and green-yellow for earth bonding), see fig. 22.
- Keep in mind that if it is supplied more than one battery pack, the connection will always be in parallel among them and the equipment. That is to say, black cable, from the negative of the UPS to the negative of the first battery pack and from this one to the negative of the second battery pack, and so on. Please, proceed in the same way for red cable for positive, blue one for half tap (N) and green-yellow for earthing.
- ⚠ Electrical discharge danger. If after starting up the UPS, it is required to disconnect the battery cabinet, the equipment has to be completely shutdown (see section 5.2). Turn off the battery fuse holder switch (Q8) located in the battery cabinet and/or fuse holder switch or switch (Q3) located in the UPS. Wait at least 5 min. till the filter capacitors have been discharged.

#### 4.3.5. Connection main protective earthing terminal (☺) and protective earth bonding terminal (⚡).

- ⚠ As this is a device with class I protection against electric shocks, it is essential to install a protective earth conductor (connect earth (☺)). Connect the conductor to the terminal (X5), before connecting the power supply to the UPS input.
- Make sure that all the loads connected to the UPS are only connected to the protective earth bonding terminal (⚡). The fact of not restricting the earthing of the load or loads and/or the batteries case/s or cabinet/s to this **single point** will create return loops to earth which will affect the quality of the power supplied.
- All of the terminals identified as protective earth bonding (⚡), are joined together, to the main protective earthing terminal (☺) and to the frame of the device.

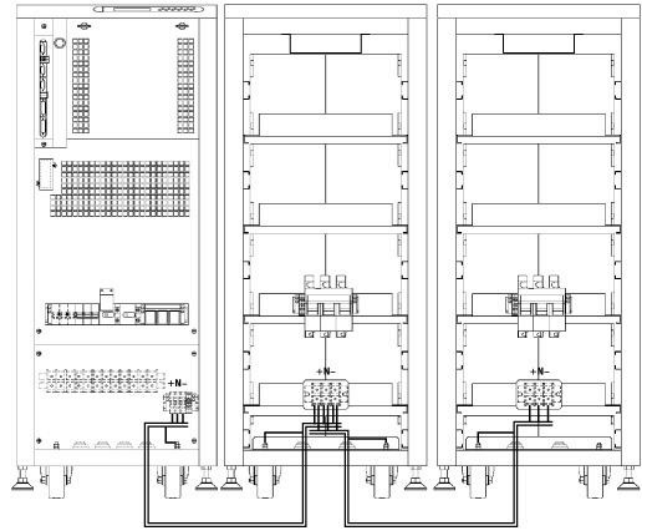

UPS Battery cabinet No. 1 Battery cabinet No. 2

Fig.22. Connection example between a UPS and two battery cabinets.

#### 4.3.6. COM port to relay. Connector (X32).

- ⚠ The communications line (COM) constitutes a very low safety voltage circuit. To preserve the quality, it must be installed aside from other lines that have dangerous voltages (power distribution line).
- The communication port to relays provides digital signals in the form of potential free contacts with a maximum applicable voltage and current of 6 A 30 V DC or 6 A 100 V AC. Both channels are in use for connecting the UPS with any machine or devices that has this standard bus (connector DB9 (X32)).
- In standard units, it consists of 5 output signalling relays (one of which is configurable), whose common point is connected to pin 5. Also an input signal can be externally supplied to perform Shutdown (5V~12V)..
- The most common use of these kinds of ports is to supply the necessary information to the file closing software.

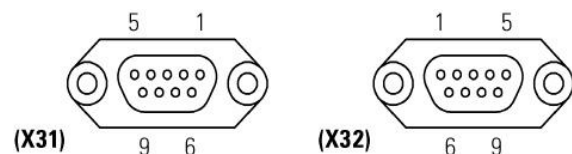

Fig.23. Connector DB9 (X31)&(X32).



Pin-out No.	Description	N.C.-N.O. Position
1	Shutdown signal +	-
2	Shutdown signal -	-
3	Configurable	Not connect
4	Discharge - Mains failure	N.C.
5	Common	-
6	Equipment in Bypass	N.O.
7	Low battery	N.O.
8	General alarm	N.O.
9	Discharge - Mains failure	N.O.

- N.C.: Normally closed contact. On the alarm having activated the contact is opened.
- N.O.: Normally **open** contact. On the alarm having activated the contact is closed.

**Table 3.** Alarms interface to relays connector DB9 (X32).

#### 4.3.7. Port COM RS-232 & RS-485. Connector (X32).

- ⚠ The communications line (COM) constitutes a very low safety voltage circuit. To preserve the quality, it must be installed aside from other lines that have dangerous voltages (power distribution line).
- In the same connector DB9 there are given both ports of communication of the equipment, the RS-232 and the RS-485. Anyway it is not possible to use them simultaneously for being mutually exclusive.
- Both channels are in use for connecting the UPS with any machine or devices that has this standard bus. The RS-232 consists of the transmission of serial data, so it is possible to send a large amount of information through a communication cable of just 3 wires.
- **Physical structure of the RS-232.**
  - Pin-out
    - Pin 2. RXD. Serial data reception.
    - Pin 3. TXD. Serial data transmission.
    - Pin 5. GND. Signal mass.
  - Communication protocol of the RS-232.

The communication protocol used is of «MASTER/SLAVE» type. The computer or computer system («MASTER») asks about a certain data, and the UPS («SLAVE») answers immediately with the required data.

Firstly it will be programmed the communication channel of the computer with the same parameters as the communication channel of the UPS. Then we will be prepared to start the communication and therefore send the UPS the first question. If we have any problem in the middle of the communication, it will be advisable to repeat the channel initialisation sequence.
- Physical structure of the RS-485.

Unlike other serial communication links, this uses only 2 wires (pins 4 and 9 of the female DB9 connector) to perform the dialogue between the systems connected to the network. The communication will be established by sending and receiving signals in differential mode, which gives the system great immunity to noise and a long reach (approx. 800 m).

- Pin-out
  - Pin 4. Output signal A (+) of the RS-485.
  - Pin 9. Output signal B (-) of the RS-485.
- Communication protocol of the RS-485.

The communication protocol of the RS-485 channel is developed to enable the UPS to dialogue with other computer systems that have this kind of channel.

  - The communication parameters RS-232 and RS-485 are the following:
    - Communication speed: 1200, 2400, 4800, 9600 or 19200 Bauds.
    - No. information bits: 8 Bits.
    - No. stop bits: 1 or 2 stop bits.
    - Parity: - Even, Odd or None.

#### 4.3.8. EPO terminals (X50).

The equipment has two terminals ready for external (remote) Emergency Power Off (EPO).

In case were needed to install a switch or button (EPO), the cable bridge that closes the circuit has to be removed from terminal strip (X50).

Switch or button (EPO) has to open the circuit between the terminal strip (X50) to activate the emergency shutdown. To restore the UPS to normal mode, invert the position of the switch or button (EPO), -close the circuit in terminal strip (X50)-.

To know the operating of (EPO), see section 5.3 of this manual.

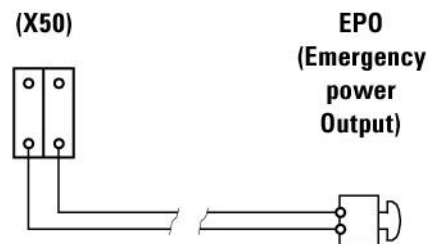

**Fig.24.** Terminals for connection of external push-button (EPO), property of the user..

## 5. Operation.

### 5.1. Start up

#### 5.1.1. Control before start up.

- Carefully make sure that all the connections have been made correctly and are sufficiently tight, respecting the labelling of the device and the instructions of chapter «4.- Installation and wiring of the unit».
- Check that the UPS switches and the batteries cabinet or cabinets are turned off (position «Off»).
- Be sure that all the loads are turned «Off».

#### 5.1.2. Start up procedure.

It is very important to operate in the established order, considering the following instructions.

- If the UPS connects to external battery cabinet, set the fuse holder switch of the battery cabinet(Q8) to «On».
- If the power supply you use to supply the UPS has a general switch, Set the general switch of the header board to «On».
- Turn the input switch (Q1a) to «On» position. The Display of the Control Panel (PC) will be turned on automatically.
- If the following alarm message appears on the Control Panel Display ...

MAINS PHASE ROT.  
UPS START INH.

screen 4.\*

.. and also an audible alarm comes on, the UPS cannot be started, because of incorrect input phase sequence. Disconnect the input switch (Q1a) and the general cut-off of the header board, swap the phases of the input terminals of the UPS according to the labelling and repeat the start-up process described up to now.

- In units with separate Bypass (UPS-B), also turn the Bypass switch (Q4) to «On» position.
- If the following alarm message appears on the Control Panel Display ...

MAINS PHASE ROT.  
UPS START INH.

screen 4.\*

... and also an audible alarm comes on, the UPS cannot be started, because of incorrect input phase sequence. Disconnect the Bypass switch (Q4) and the general cut-off of the header board, swap the phases of the input bypass terminals of the UPS according to the labelling and repeat the start-up process described up to now.

At this point, with no alarm active, green LED indications of Input Voltage OK, and orange LED indication of Unit on Bypass should light ((a), (b) from Fig. 26).

Turn the output switch (Q2) to «On», the output terminals of the UPS will supply voltage through the bypass line.

Start up the inverter. The start up operation will be done through the keypad of the control panel ((3) from Fig. 26). Go down to «CONTROL & STATUS OF THE UNIT» submenu (screen 1.0), and then right only once. You will get to screen 1.1, asking you to start the unit up by pressing (ENT). Do so, and then confirm operation by pressing (ENT) again. See following screen diagram (Fig. 25).

After a few seconds, the UPS will be running (rectifier working, inverter working), and the output will be supplied from the inverter

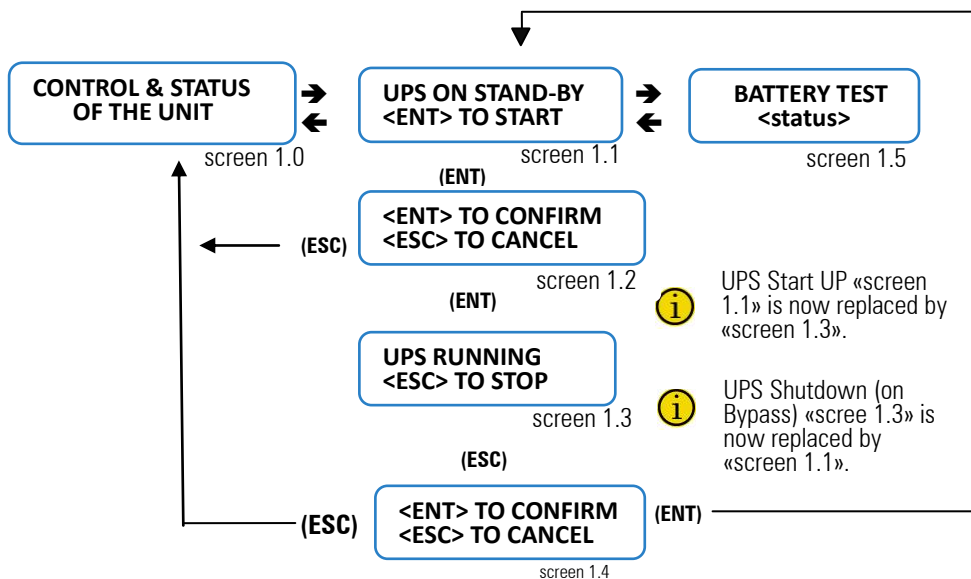

Fig.25. Procedure start-up / shutdown.

- Before continuing, be sure that the LED indication (c) Inverter is working is lit (green), and (b) Unit on Bypass is turned OFF (see Fig. 26). Otherwise please contact with the S.T.S. (Service and Technical Support).
- Once the rectifier is completely working, it starts a process of equalization (DC bus voltage starts to equalize with battery voltage). After a few seconds (depending on the battery level), an alarm message like this ...

**BATT. SWITCH OPEN  
SWITCH IT ON**

screen 4\*

...it displays that the equalising process has been finished, and IN THIS MOMENT ONLY is when the battery fuse holder switch or switch of UPS (**Q3**) can be turned on.

DO NOT TRY to close any battery fuse holder switch at any other moment, because this operation could damage the equipment and/or cause possible accidents. They can only be turned on by following the quoted previous steps.

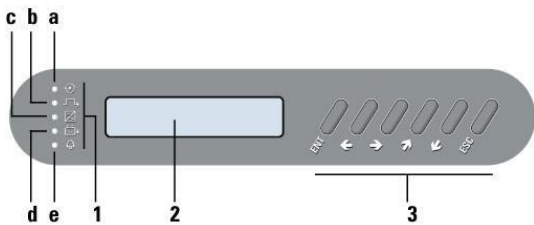

Fig.26. LED indications control panel (PC)

- If the system has outgoing distribution protections, switch them «On».
- Start up the loads to be supplied in a progressive way. The system is started up completely, and the loads are protected through the UPS.

### 5.2. Complete UPS shutdown.

- Shutdown the loads.
- If the system has outgoing distribution protections, switch them «Off».
- Shutdown the inverter. Through the keypad of the control panel ((3) from Fig. 26), go down to "CONTROL & STATUS OF THE UNIT" submenu (screen 1.0), and then right only once. You will get to screen 1.3, asking you to shutdown the unit by pressing (ESC). Do so, and then confirm operation by pressing (ENT), see Fig 25.
- Turn the output switch (**Q2**) to «Off» position.
- In standard units, set the input switch (**Q1a**) to «Off» position. In B units, set the input switch (**Q1a**) and static bypass switch (**Q4**) to «Off» position.
- Turn fuse holder switch from battery cabinet (**Q8**) and/or battery fuse holder switch or switch from UPS (**Q3**), to «Off».

- Cut the power supply of the UPS and the bypass with the cut-off or general switch of the header board. The system will be completely deactivated.
- ⚠ **Electrical discharge hazard.** If after shutdown of the equipment, it is required to disconnect the separate battery pack/s, wait several minutes (5 min. approx), till the electrolytic capacitors have been discharged.
- The equipment is completely shutdown.

### 5.3. Emergency power off (EPO) operation.

Emergency Power Off (EPO) is equivalent to a complete unit system halt:

- All UPS converters are turned off (rectifier and inverter off).
- No output voltage is supplied to the loads.  
That function can be commanded through 2-way connector (**X50**).

See table below for operation:

E.P.O. function	Activation (perform System Halt)	Return to normal-mode.
Terminals ( <b>X50</b> ). Normally closed circuit by means of the provided cable bridge (it allows an external switch (EPO)).	Remote button or switch has to be opened permanently in terminal strip ( <b>X50</b> ).	The equipment has to be shutdown and deenergized completely (turn off all switches), wait till DC bus is discharged (all LEDs and LCD have to be turned off). The equipment has to be started up according to section "5.1.2. Start up procedure".

Table.4. Emergency Power Off (EPO) operation.



## 5.4. Bypass manual switch (MAINTENANCE).

### 5.4.1. Principle of operation.

The integrated manual bypass of the UPS is a very useful element, but undue use can have irreversible consequences both for the UPS and for the loads connected to its output. It is therefore important to handle it as described in the following paragraphs.

### 5.4.2. Transfer to maintenance bypass.

Procedure for passing from normal operation to maintenance bypass:

- Shutdown the inverter. Through the keypad of the control panel ((3) from Fig. 26), go down to "CONTROL & STATUS OF THE UNIT" submenu (screen 1.0), and then right only once. You will get to screen 1.3, asking you to shutdown the unit by pressing (ESC). Do so, and then confirm operation by pressing (ENT), see Fig 25.
- Remove the screws to that fixes the mechanical block (BL).
- Remove the mechanical block (BL) of the manual bypass switch (Q5) and set it to «On» position.
- Set the output switch (Q2) to «Off» position.
- Set the Battery Fuse Holder or battery switch (Q3) to «Off». Besides, in models with independent battery pack/s also turn Battery Fuse Holder (Q8) of each pack to «Off».
- In standard units, set the input switch (Q1a) to «Off» position. In B units, set the input switch (Q1a) and static bypass switch (Q4) to «Off» position.

The UPS is supplying output voltage directly from the mains through the manual bypass in units or from the mains of the static line bypass in the version B units, through the manual bypass. The UPS is completely shutdown and inactive.

### 5.4.3. Transfer to normal operation.

Procedure for switching from maintenance bypass to normal operation:

- In model with external battery cabinet, set fuse holder switch from battery cabinet (Q8) to «On» position.
- In standard units, set the input switch (Q1a) to «On» position. In B units, set the input switch (Q1a) and static bypass switch (Q4) to «On» position.
- Set the output switch (Q2) to «On» position.
- Set the manual bypass switch (Q5) to «Off» position and refit the mechanical block (BL) and the screws (t2).

⚠ It is an essential requirement for safety to refit the mechanical block (BL), as this avoids dangerous handling for the life of the UPS and the loads connected to it.

- Start up the inverter. The start up operation will be done through the keypad of the control panel ((3) from Fig. 26). Go down to «CONTROL & STATUS OF THE UNIT» submenu (screen 1.0), and then right only once. You will get to screen 1.1, asking you to start the unit up by pressing (ENT). Do so, and then confirm operation by pressing (ENT) again. See following screen diagram (Fig. 25).

The UPS supplies output voltage entirely protected against voltage variations, electric noise, etc.

- Wait for alarm message to appear:

**BATT. SWITCH OPEN  
SWITCH IT ON**

screen 4\*

- Battery fuse holder switch or switch from UPS (Q3) can only be turned «On» when the previous alarm message has been cancelled.

DO NOT TRY to close any battery fuse holder switch at any other moment, because this operation could damage the equipment and/or cause possible accidents. They can only be turned on by following the quoted previous steps.

- The UPS supplies output voltage entirely protected against cuts, micro cuts, voltage variations, electric noise, etc.

## 6. CONTROL PANEL AND DISPLAY DESCRIPTION.

### 6.1. CONTROL PANEL PARTS.

- (LED's) LED indications:
- (a) Rectifier Input Voltage OK (green).
  - (b) Unit on Bypass (orange).
  - (c) Inverter is working (green).
  - (d) Unit working from batteries -mains failure- (red).
  - (e) In case of any alarm of the unit (red).
- (2) Character Display
- (3) Keyboard
- ENT «Enter» key. Confirmation of orders, program values (or other specified functions)
- ← «Left» key for submenu navigation, or cursor displacement.
- «Right» key for submenu navigation, or cursor displacement.
- ↶ «Up» key for menu navigation, or digit modification.
- ↷ «Down» key menu navigation, or digit modification.
- ESC «Escape» key. Return to main screen, cancel/finish programming (or other specified functions).
- ENT, ↶ When pressed simultaneously at least during 3 secs., equivalent to an Emergency Power Off (EPO), turn-off any voltage at the output (see section 5.3).

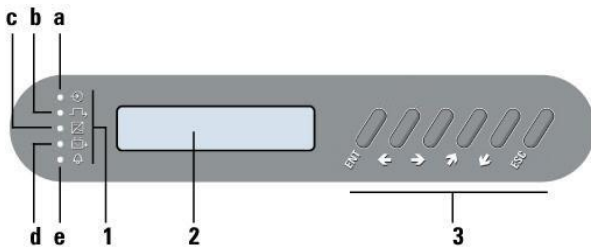

Fig.27. Control panel parts.

### 6.2. BASIC FUNCTIONS OF KEYBOARD FROM SYNOPTIC.

- Through keys advance (↶) and return (↷), there is access to all the menus of the LCD panel, being able to move from one to another.
- Through keys right (→) or left (←), there is access to the screens of all the submenus of the LCD panel, being able to move from one to another with themselves.
- Key (ENT), has different purposes depending on the menu we are:
  - Setting values. Press key (ENT) to activate the function setting, the figures in the screen blink. With keys (→)-(←) the character to set is selected and with keys (↶)-(↷) the value is selected. To confirm press (ENT). Next field will blink, to continue doing settings proceed in the same way or press (ESC) to return to no-setting situation.

- Validation of orders or commands.
  - When pressing key (ESC) from any screen of any submenu, we go back to main screen (Screen 0.0), unless we are in any screen of «Parameters» menu and setting any of them. If so, the first pulsation of key (ESC) will stop blinking the value, and second one to go back to main screen.
- Notes related with the screen map (see figure 29):
  - Some screens have a certain number of «-» characters. Each one of it, means one character so the maximum length of the field will be determined by the number of them.
  - Each screen is labelled with a number located in its right bottom corner. It is only included as a mere reference for its next description and explanation.
  - Note (\*1): means the hidden programming screens through the password (\*\*\*\*\*) in «screen 1....». This safety level avoids that non-authorized staff can alter or modify any setting.

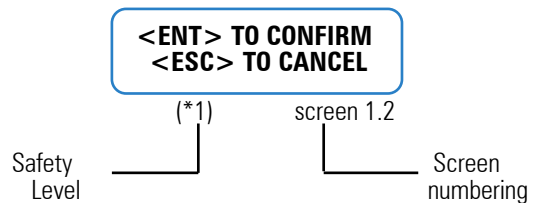

Fig.28. Notes related with the screens.

### 6.2.1. Messages menus and classification in submenus.

- Use (↶) and (↷) keys to choose between different menus (0.0, 1.0, ..., 7.0).
- Use (→) and (←) keys to move inside submenu screens.

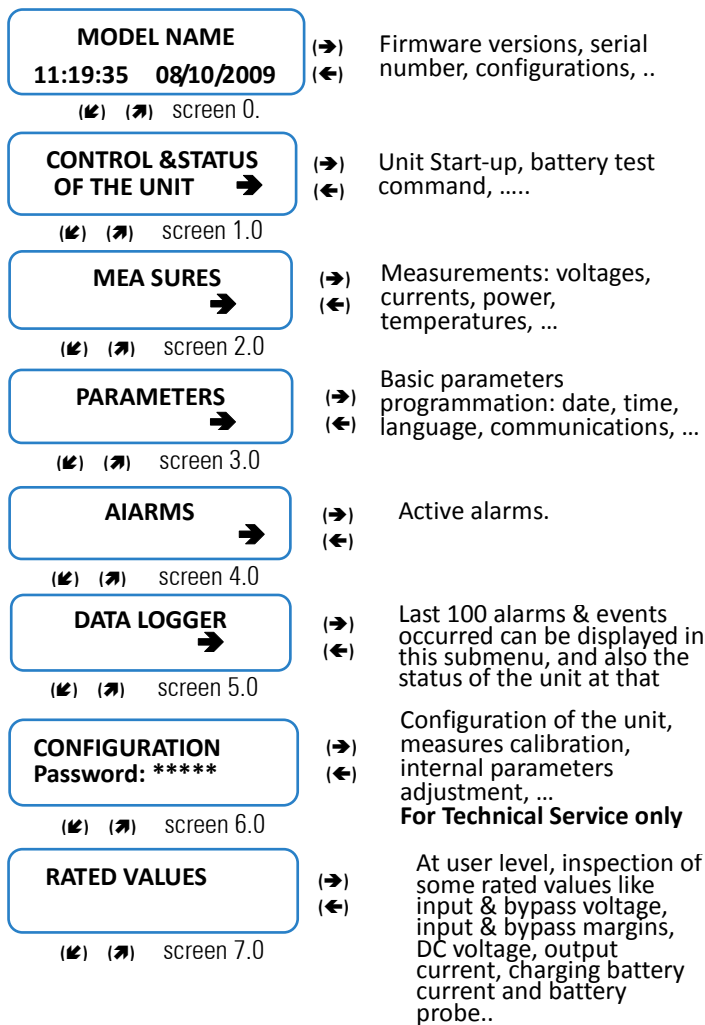
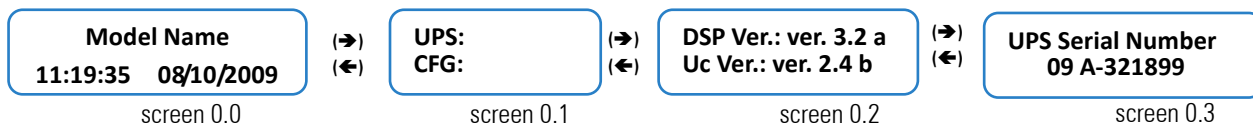

Fig.29. Display messages menus and classification in submenus.

### 6.3. SCREEN DESCRIPTION.

#### 6.3.1. Main level (screen menu 0.0). See Fig. 30.

• **Screen 0.0:** Main presentation screen, with time and date indication.



When pressing key (ESC) from any screen of any submenu, we go back to main screen (Screen 0.0),

Fig.30. Screen 0.0 «Initial» and its submenus.

• **Screen 0.1:** UPS Status ("UPS:", 1<sup>st</sup> row) and configuration ("CFG:", 2<sup>nd</sup> row). In the first row, there are two fields, first to show general state of the converters, and second to show origin of the voltage on the output. These two fields are separated by a " , ":

□ Possible state of the converters:

- «Shutdown» Rectifier and Inverter stopped or blocked.
- «Start» UPS converters (rectifier and inverter) are starting, but still not ready.
- «Normal» UPS is running in normal mode: mains present, rectifier running, output on inverter. Loads are protected.
- «Dischar.» Mains failure. UPS running on back-up mode (rectifier stopped, inverter running).

□ Origin of the output:

- «OFF» No voltage supplied at the output (either EPO pressed, or severe problem on the unit).
- «Invert» Inverter voltage is supplied at the output. Loads are protected.
- «Bypass» Bypass voltage is supplied at the output. Either the unit is manually stopped, or overloaded, or other possible problems on the inverter.

In the second row we have information about the configuration (single or parallel) of the unit:

□ Configuration and status of the unit:

- «Single:» "Single" connection.
- «Parallel-Single» Parallel connection. Unit is on "single" state.
- «Parallel-Master» Parallel connection. Unit is on "master" state.
- «Parallel-Slave» Parallel connection. Unit is on "slave" state.

Examples:

a)

**UPS: Normal, Invert.  
CFG: Single**

b)

**UPS: Shutdown, Bypass  
CFG: Parallel-Master**

• **Screen 0.2:** Internal firmware versions of both Digital Signal Processor ("DSP Ver:") and microcontroller ("uC Ver:"). In the sample screen, "ver. 3.2 a" and "ver. 2.4 b" respectively.

• **Screen 0.3:** UPS Serial Number, expressed with 10 characters. Possible characters ranges are "0"- "9", "A"- "Z" and also " " (blank space), "-". See sample screen.

6.3.2. "CONTROL & STATUS OF THE UNIT" Level (screen menu 1.0). See Fig. 31.

- **Screens 1.1, 1.3 and confirmation screen (1.2 / 1.4):** to start and stop the unit through the control panel.  
For procedure for starting and stopping, see chapters 5.1.2 and 5.2.
- **Screen 1.5 and confirmation screen (1.2 / 1.4):** to order a battery test. On the second row, information about the battery test is given.  
Possible messages:  
"NOT AVAILABLE": The battery test is not available.  
"PRESS <ENTER>": Press <ENTER> to run the battery test.  
"EXECUTING": The battery test is running.  
"SUCCESSFUL": The battery test has been successful.  
"NOT SUCCESSFUL": The battery test has not been successful.

6.3.3. "MEASURES" level (screen menu 2.0). See Fig. 32.

Due to the four different configurations of the UPS...

- 1.- Three phase input / Three phase output (III/III).
- 2.- Three phase input / Single phase output -N- (III/I).
- 3.- Single phase input /Single phase output -L- (I/I).
- 4.- Single phase input /Three phase output -M- (I/III).

... the quantity of showed screens and their respective readings can vary depending on each case.

Table 5 shows the screens that ARE NOT AVAILABLE in some configurations, from "three phase input / three phase output" configuration as maximum conceptual exponent and represented in submenu of figure 32, which shows reading values as an example. For single phase equipments, the showed readings will be according to its condition.

NOT AVAILABLE reading screens according to the UPS configuration.			
(III / III)	-N- (III / I)	-L- (I / I)	-M- (I / III)
-	-	2.1	2.1
-	-	2.14	2.14
-	-	2.15	2.15
-	-	2.16	2.16
-	-	2.17	2.17
-	-	2.18	2.18
-	-	2.19	2.19
-	2.22	2.22	-
-	2.23	2.23	-
-	2.24	2.24	-
-	2.25	2.25	-
-	2.26	2.26	-
-	2.27	2.27	-
-	2.30	2.30	-

Table 5. NOT AVAILABLE reading screens according to the UPS configuration.

- **Screen 2.1:** input voltages phase to phase (units 0.1V).
- **Screen 2.2:** three phase input voltages phases to neutral or for single phase input phase to neutral (units 0.1V).
- **Screen 2.3:** input current per each phase for three phase equipments or per phase for single phase equipment (units 0.1A).
- **Screen 2.4:** three phase output voltages phases to neutral, or for single phase output phase to neutral (units 0.1V).
- **Screen 2.5:** output current per each phase for three phase equipments or per phase for single phase equipment (units 0.1A).
- **Screen 2.6:** three phase inverter output voltages phases to neutral, or for single phase inverter output phase to neutral (units 0.1V).
- **Screen 2.7:** inverter output current per each phase for three phase equipments or per phase for single phase equipment (units 0.1A).

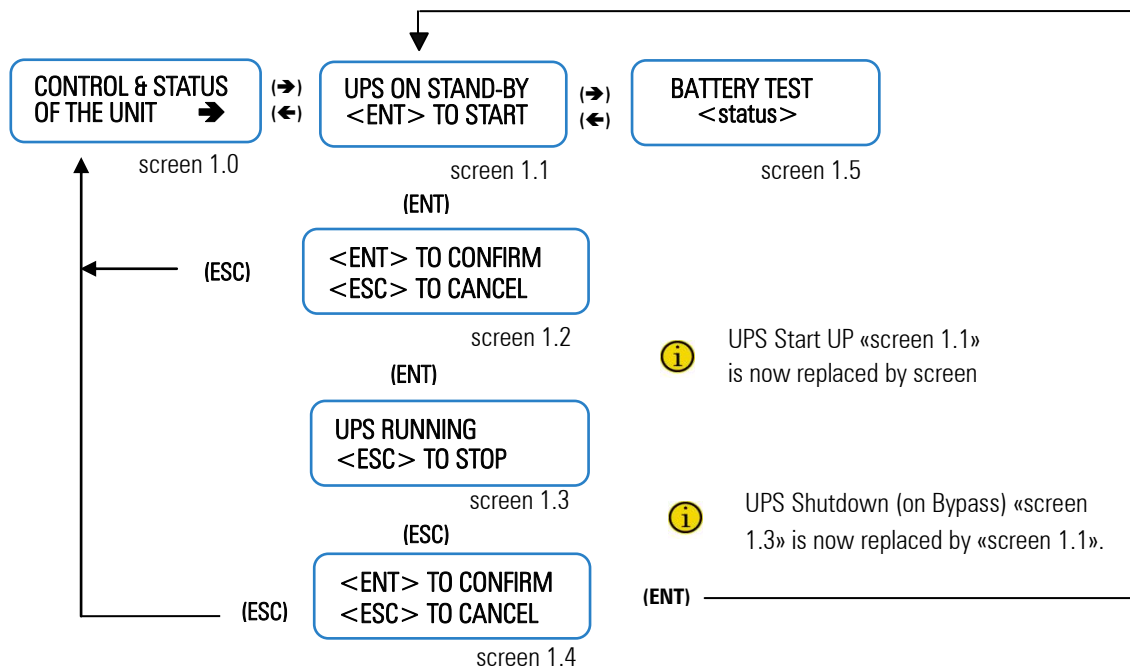
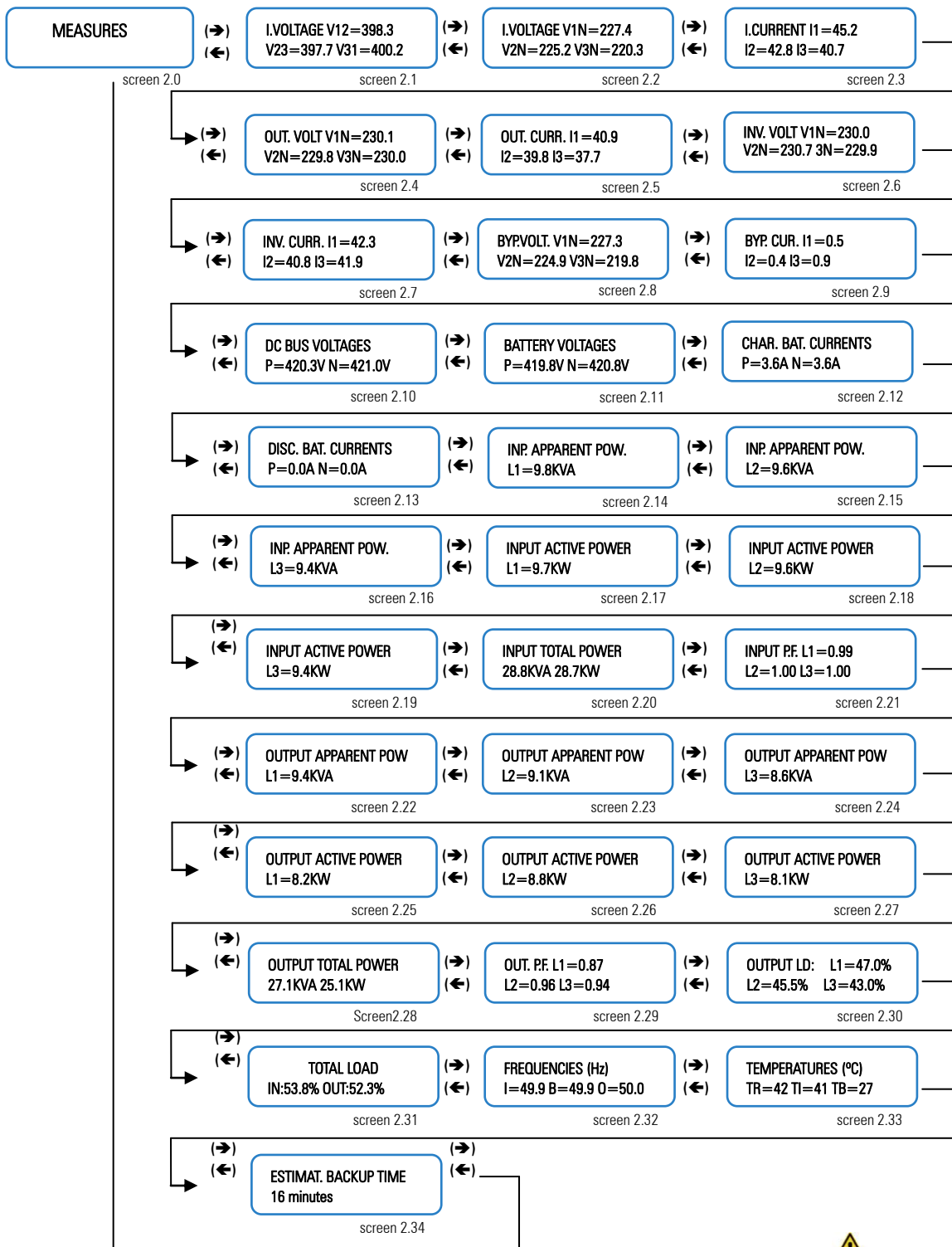

Fig.31. Screen submenus 1.0. Diagram for starting and stopping UPS.



When pressing key (ESC) from any screen of any submenu, we go back to main screen (Screen 0.0).

Fig.32. Screen 2.0 «Measures» and its submenus.

- Showed readings in screens 2.1 to 2.9, 2.21, 2.29 and 2.30 will be according to the input and output topologies, depending if they are single phase (there will be one figure only in the LCD panel) or three phase (there will be three figures that correspond to the three phases).
- NOT AVAILABLE reading screens for each configuration are stated in table 5.

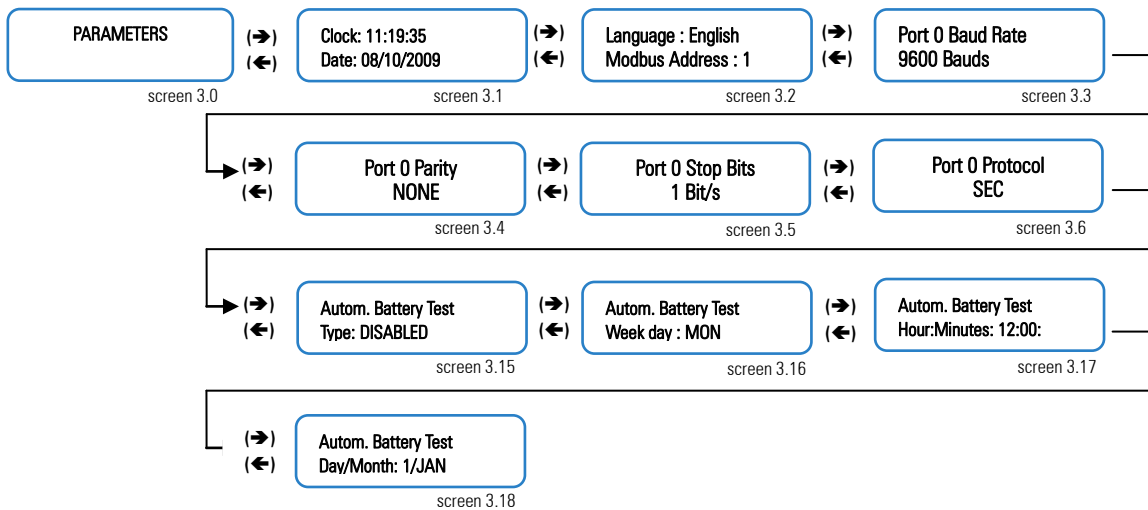

When pressing key (ESC) from any screen of any submenu, we go back to main screen (Screen 0.0),

**Fig.33.** Screen 3.0 «Parameters» and its submenus.

- **Screen 2.8:** three phase bypass voltages phases to neutral, or for single phase bypass phase to neutral (units 0.1V).
- **Screen 2.9:** bypass current per each phase for three phase equipments or per phase for single phase equipment (units 0.1A).
- **Screen 2.10:** DC bus voltages positive and negative (units 0.1V).
- **Screen 2.11:** battery voltages positive and negative (units 0.1V).
- **Screen 2.12:** charge battery currents positive and negative (units 0.1A).
- **Screen 2.13:** discharge battery currents positive and negative (units 0.1A).
- **Screen 2.14:** input apparent power of L1 (units 0.1kVA).
- **Screen 2.15:** input apparent power of L2 (units 0.1kVA).
- **Screen 2.16:** input apparent power of L3 (units 0.1kVA).
- **Screen 2.17:** input active power of L1 (units 0.1kW).
- **Screen 2.18:** input active power of L2 (units 0.1kW).
- **Screen 2.19:** input active power of L3 (units 0.1kW).
- **Screen 2.20:** total input apparent power and active power (units 0.1kVA & 0,1kW).
- **Screen 2.21:** input power factor per each phase in three phase equipments or power factor for single phase equipments (units 0.01).
- **Screen 2.22:** apparent output power L1 (units 0.1kVA).
- **Screen 2.23:** apparent output power L2 (units 0.1kVA).
- **Screen 2.24:** apparent output power L3 (units 0.1kVA).
- **Screen 2.25:** active output power L1 (units 0.1kW).
- **Screen 2.26:** active output power L2 (units 0.1kW).

- **Screen 2.27:** active output power L3 (units 0.1kW).
- **Screen 2.28:** total apparent and active powers (units 0.1kVA and 0,1kW).
- **Screen 2.29:** output power factor of each phase for three phase equipments or power factor for single phase equipments (units 0.01).
- **Screen 2.30:** output load of three phases (units 0.1%).
- **Screen 2.31:** total input load and total output load (units 0.1%).
- **Screen 2.32:** input, bypass and output frequencies (units 0.1Hz).
- **Screen 2.33:** rectifier, inverter and battery temperatures (units 1°C).
- **Screen 2.34:** estimated backup time (units 1minute).



Shown readings in screens 2.1 to 2.9, 2.21, 2.29 and 2.30 will be according to the input and output topologies, depending if they are single phase (there will be one figure only, in the LCD panel) or three phase (there will be three figures that correspond to the three phases).

#### 6.3.4. "PARAMETERS" level (screen menu 3.0). See Fig. 33.

- **Screen 3.1:** In the first row you can program the time "hh:mm:ss" (hours/minutes/seconds) and in the second row you can program the date "dd/mm/yy" (day/month/year).
  - **Screen 3.2:** In the first row you can select the display language between the following options:
    - "Español"
    - "English"
    - "Francais"
- In the second row you can program the Modbus Address. The range of addresses goes from 1 to 247.
- **Screen 3.3:** In this screen you can program the BAUD RATE of communication port #0. The options are the following:
    - "1200"
    - "2400"
    - "4800"

- ❑ "9600"
- ❑ "19200"

• **Screen 3.4:** In this screen you can program the PARITY type of communication port #0. The options are the following:

- ❑ "NONE"
- ❑ "ODD"
- ❑ "EVEN"

• **Screen 3.5:** In this screen you can program the number of STOP BITS of communication port #0. The options are the following:

- ❑ "1"
- ❑ "12"

• **Screen 3.6:** In this screen you can program the protocol type of communication port #0. The options are the following:

- ❑ "SEC"
- ❑ "MODBUS"

• **Screen 3.15:** This is the screen for programming the frequency of the automatic battery test. The options to be programmed are the following:

- ❑ "DISABLED": The automatic battery test is disabled.
- ❑ "WEEKLY": The automatic battery test runs once per week.
- ❑ "MONTHL": The automatic battery test runs once per month.
- ❑ "YEARLY": The automatic battery test runs once per year.

• **Screen 3.16:** This screen appears independently on the last screen, but it only have sense to be programmed if the automatic battery test runs once per week. The options to be programmed are the following:

- ❑ "MON": the selected day to run weekly the battery test is monday.
- ❑ "TUE": the selected day to run weekly the battery test is tuesday.
- ❑ "WED": the selected day to run weekly the battery test is wednesday.
- ❑ "THU": the selected day to run weekly the battery test is thursday.
- ❑ "FRI": the selected day to run weekly the battery test is friday.
- ❑ "SAT": the selected day to run weekly the battery test is saturday.
- ❑ "SUN": the selected day to run weekly the battery test is sunday.

• **Screen 3.17:** This screen appears independently on the last screen, but it only have sense to be programmed if the automatic battery test is enabled. In this screen you can program the time "hh:mm" (hours/minutes) in 24h format.

• **Screen 3.18:** This screen appears independently on the last screen, but it only have sense to be programmed if the automatic battery

test runs monthly or yearly. In this screen you can program the day from 1 to 31 and the month selecting one of the following options:

- ❑ "JAN": the selected month to run yearly the battery test is january.
- ❑ "FEB": the selected month to run yearly the battery test is february.
- ❑ "MAR": the selected month to run yearly the battery test is march.
- ❑ "APR": the selected month to run yearly the battery test is april.
- ❑ "MAY": the selected month to run yearly the battery test is may.
- ❑ "JUN": the selected month to run yearly the battery test is june.
- ❑ "JUL": the selected month to run yearly the battery test is july.
- ❑ "AUG": the selected month to run yearly the battery test is august.
- ❑ "SEP": the selected month to run yearly the battery test is september.
- ❑ "OCT": the selected month to run yearly the battery test is october.
- ❑ "NOV": the selected month to run yearly the battery test is november.
- ❑ "DEC": the selected month to run yearly the battery test is december.

### 6.3.5. "ALARMS" level (screen menu 4.0). See Fig. 34.

By means of key (➡) active alarms are displayed, being able to move from one to another inside of the alarm list with the keys (➡) or (⬅).

If there is not any alarm, it will not be possible to go forward with key (➡).

Figure 34 is showing just only one alarm as an example, but there could be some of them, the active ones. In table 6, there are all the possible alarms displayed in the display LCD. Also, alarm message screens may appear blinking and replacing any other screen (even in different menu or submenu) currently displayed. By pressing (ENT), blinking alarm message is acknowledged and previous screen is displayed again.

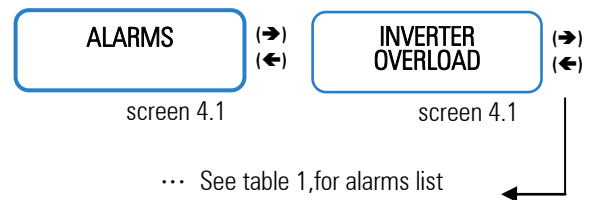

Fig.34. Screen 4.0 «Alarms» and its submenus.

• **Screen 4.1:** This alarm indicates that the rectifier is overloaded. The rectifier overload appears when the input current of any phase is greater than the following ratio:

$$lin-ovl = 0,326 \times Pout / Vout_{p-n}$$

Where:

- lin-ovl is Overload Input Current (A)



- Pout is Rated Output Apparent Power (VA)
- Vout\_p-n is Rated Output Voltage phase-to-neutral (V)

- **Screen 4.2:** This alarm indicates that the inverter is overloaded. The inverter overload appears either when the output current of any phase is greater than the rated output current

$$I_{out-ovl} = P_{out} / (V_{out\_p-n} * 3)$$

Where:

- Iout is rated Output Current (A)
- Pout is Rated Output Apparent Power (VA)
- Vout\_p-n is Rated Output Voltage phase-to-neutral (V)

or when the total output active power is greater than the following formula:

$$P_{act\_out-ovl} = P_{out} * 0,8$$

Where:

- Pact\_out-ovl is the Overload Output Active Power (W)
- Pout is Rated Output Apparent Power (VA)

- **Screen 4.3:** This alarm appears when the input the unit is under main failure condition and the level of battery is lower than 11,5V/bat.
- **Screen 4.4:** This alarm appears when the inverter output voltage phase to neutral in any phase is out of margins over +/-6%.
- **Screen 4.5:** This alarm appears when there is an offset voltage higher than 5V, in any phase of the inverter output voltage phase to neutral.
- **Screen 4.6:** When the maintenance bypass switch is ON the UPS inverter will not be available.
- **Screen 4.7:** The mains failure occurs when in any phase, the input voltage phase to neutral is out of the set margins (+15%/-20% by default) or the input frequency is out of the set margins (± 0,5Hz by default).
- **Screen 4.8:** When the inverter or PFC temperature sensors measure temperatures over the programmed values (70°C by default).
- **Screen 4.9:** This message appears when the battery switch is OFF and the DC bus is charged to the battery voltage level, to inform the user to switch ON the battery switch.
- **Screen 4.10:** This screen indicates that the bypass input voltage or the bypass input frequency are out of margins. These margins are programmable but by default the bypass voltage range is +12%/-17% and the bypass frequency range is ±0.5Hz.
- **Screen 4.11:** The UPS is on bypass for any reason. It must be restarted by display keypad.
- **Screen 4.12:** This is an alarm for parallel systems. It appears when some UPS of the parallel system block because the maintenance bypass switch of any unit is switched ON.
- **Screen 4.13:** This alarm indicates that the CAN BUS #1 fails. This communication channel is used for remote control.
- **Screen 4.14:** This alarm indicates that the CAN BUS #2 fails. This channel is used for data communication between UPS, in a parallel system.

- **Screen 4.15:** This alarm appears at the estimated end of life of the battery bank. The revision and replacement of some batteries will be necessary to be done by calling the S.T.S. (Service and Technical Support) department.

Representation in display LCD	Alarms	Ref.
<b>RECTIFIER OVERLOAD</b>	RECTIFIER	4.1
<b>INVERTER OVERLOAD</b>	INVERTER	4.2
<b>MAINS FAILURE</b>		4.3
<b>LOW BATTERY LEVEL</b>		4.4
<b>INVERTER VOLTAGE OUT OF MARGINS</b>		4.5
<b>DC VOLT. DETECTED AT THE OUTPUT</b>		4.6
<b>MAINTENANCE BYP. INVERTER NOT AVAIL.</b>		4.7
<b>MAINS FAILURE BATTERY DISCHARGIG</b>	UPS	4.8
<b>HIGH TEMPERATURE REDUCE OUTPUT LOAD</b>		4.9
<b>BATT. SWITCH OPEN SWITCH IT ON</b>		4.10
<b>BYPASS FAILURE NOT SYNCHRONISED INV</b>		4.11
<b>UPS ON BYPASS INITIALISE THE UPS</b>		4.12
<b>SOME UNIT BLOCKED DUE TO MAINT. BYPASS</b>		4.13
<b>CAN BUS 1 COMMUNICATION FAIL.</b>		4.14
<b>CAN BUS 2 COMMUNICATION FAIL.</b>		4.15
<b>END OF BATTERY LIFE ALARM</b>		4.16
<b>BATT. TEMPERATURE TOO HIGH</b>		4.17
<b>BATTERY TEST NOT SUCCEDED</b>		4.18
<b>BAT.DISCONNECTION SHUTDOWN &amp; RESTART</b>		4.19
<b>MAINS PHASE ROT. UPS START INH.</b>		4.20
<b>BYPASS PHASE ROT. UPS START INH.</b>		RECTIFIER STOPS
<b>INP. VOLTA. WRONG RECTIFIER STOP</b>	4.22	
<b>RECTIFIER DESATS. RECTIFIER STOP</b>	4.23	
<b>DSP INTERN. ERROR RECTIFIER STOP</b>	4.24	
<b>INPUT PHASE ROT. RECTIFIER STOP</b>	INVERTER STOPS	4.25
<b>INVERTER DESATS. INVERTER STOP</b>		4.26
<b>INVERTER OVERLOAD INVERTER STOP</b>		



Representation in display LCD	Alarms	Ref.	
SHUTDOWN COMMAND INVERTER STOP	INVERTER STOPS	4.27	
MAINTENANCE BYP. INVERTER STOP		4.28	
PARAL. SYS. DISC. INVERTER STOP		4.29	
HIGH OVERLOAD INVERTER STOP		4.30	
OVERTEMPERATURE INVERTER STOP		4.31	
RECTIFIER OVERLO. INVERTER STOP		4.32	
DSP INTERN. ERROR INVERTER STOP		4.33	
OUT SHORT-CIRCUIT INVERTER STOP		4.34	
BYPASS PHASE ROT. INVERTER STOP		4.35	
DSP INTERN. ERROR UPS STOP		UPS STOPS	4.36
LOW BATTERY UPS STOP			4.37
EMERGE. POWER OFF NO OUTPUT VOLTAGE	BYP STOPS	4.38	
OUT SHORT-CIRCUIT NO OUTPUT VOLTAGE		4.39	
DSP INTERN. ERROR UPS BLOCK ALL		4.40	
DC BUS VOLT WRONG RECTIFIER BLOCK	RECTIFIER BLOCKS	4.41	
RECTIFIER BLOCKED BLK. UPS -> BLK. REC		4.42	
RECTIFIER DESATS. RECTIFIER BLOCK		4.43	
VOLTAGE RAMP ERR. RECTIFIER BLOCK		4.44	
INTERN. EXE. ERROR RECTIFIER BLOCK		4.45	
DSP INTERN. ERROR RECTIFIER BLOCK		4.46	
CONTACTOR T. FAIL RECTIFIER BLOCK		4.47	
VOLTAGE RAMP ERR. INVERTER BLOCK	INVERTER BLOCKS	4.48	
OUTPUT DC VOLTAGE INVERTER BLOCK		4.49	
INVERTER BLOCKED BLK. UPS -> BLK. INV		4.50	
INVERTER DESATS. INVERTER BLOCK		4.51	
INTERN. EXE. ERROR INVERTER BLOCK		4.52	
DSP INTERN. ERROR INVERTER BLOCK		4.53	
UPS BLOCKED BLK. REC -> BLK. UPS	UPS BLOCKS	4.54	
INTERN. INI. ERROR UPS BLOCK (DSP)		4.55	
INTERN. EXE. ERROR UPS BLOCK (DSP)		4.56	

Representation in display LCD	Alarms	Ref.
UPS BLOCKED BLK. INV -> BLK. UPS	UPS BLOCKS	4.57
INTERN. COM. ERROR UPS BLOCK (DSP)		4.58
PARAL. SYS. DISC. UPS BLOCK		4.59
UPS OVERTEMPERAT. UPS BLOCK		4.60
RECTIFIER OVERLO. UPS BLOCK		4.61
INVERTER DESATS. UPS BLOCK		4.62
DSP INTERN. ERROR UPS BLOCK		4.63
PFC & INV BLOCK. UPS BLOCK		4.64

Table .6 Alarm list displayed in the LCD panel.

- **Screen 4.16:** The temperature of battery cabinet (in case of separate battery cabinet) or battery place (in case of battery are located inside the UPS) is higher than 40°C.
- **Screen 4.17:** If battery test (automatic or manual) is finished unsuccessfully, this alarm will appear.
- **Screen 4.18:** Two possible reasons:
  - During the unit start up, a message appears indicating that the battery switch can be switched ON. After some period of time without switching ON, this alarm appears.
  - When the unit is running under normal conditions, and the battery switch is switched OFF.
- **Screen 4.19:** When the mains is connected during the start up, a phase rotation error is detected and the start up procedure is inhibited.
- **Screen 4.20:** When the bypass is connected during the start up, a bypass phase rotation error is detected and the start up procedure is inhibited.
- **Screen 4.21:** This alarm appears when in any phase, the rectifier input voltage phase to neutral is out of the set margins (+15%/-20% by default) or the rectifier input frequency is out of the set margins ( $\pm$  0,5Hz by default). Then the rectifier is shut down.
- **Screen 4.22:** This alarm appears when any IGBT in the rectifier side, desaturates the number of times programmed by display (50 by default).
- **Screen 4.23:** This alarm appears when there is a (\*) DSP Internal Error in the rectifier module, shutting down the rectifier immediately. There will be 3 more retries before the rectifier blocking.
- **Screen 4.24:** When a mains phase rotation error is detected and under these conditions the rectifier is tried to be turned ON, an input phase rotation alarm appears shutting down the rectifier.
- **Screen 4.25:** This alarm appears when any IGBT in the inverter side, desaturates the number of times programmed by display (200 by default).
- **Screen 4.26:** When the inverter output is overloaded, depending on the level of this overload, the inverter will be shut down after some time according to the UPS overload curve and this alarm will appear.

- **Screen 4.27:** When an external shutdown signal is enabled, the inverter will shut down appearing this message.
- **Screen 4.28:** When the inverter is running and the maintenance bypass switch is turned ON the inverter shuts down immediately.
- **Screen 4.29:** This alarm appears when, in a parallel system, one UPS goes to battery mode. The inverter will shut down.
- **Screen 4.30:** This message indicates that one UPS is running over 160% of load in a parallel system.
- **Screen 4.31:** When an overtemperature is detected by the PFC or inverter temperature sensors, after 1 minute time the inverter will be turned off automatically. If overtemperature condition remains after another 1 minute with the rectifier working, rectifier is also blocked (alarm 4.60).
- **Screen 4.32:** When the rectifier is overloaded, depending on the level of this overload, the inverter will be shut down after some time according to the rectifier overload curve and this alarm will appear. If this overload is still present with the inverter switched off, the rectifier will be blocked after 30" and a blocking alarm 4.61 will appear.
- **Screen 4.33:** This alarm appears when there is a (\*) DSP Internal Error in the inverter module, shutting down the inverter immediately. There will be 4 more retries before the inverter blocking.
- **Screen 4.34:** This alarm appears when an output short-circuit is detected limiting the output RMS current up to the set value (150% of nominal current by default). The short-circuit is detected when the output voltage phase to neutral is lower than 8% of nominal voltage. The system will retry twice to restart.
- **Screen 4.35:** With the inverter is running, if there's a bypass phase rotation error, the inverter will shut down.
- **Screen 4.36:** This alarm appears when there is a (\*) DSP Internal Error in the UPS module, shutting down the UPS immediately. There will be 2 more retries before the UPS blocking.
- **Screen 4.37:** This alarm describes that on battery mode, the battery bank reaches the 10.5V/bat. This is the end of backup time, shutting down the UPS.
- **Screen 4.38:** The EPO (Emergency Power Off) switch is ON. The UPS and the static bypass are switched off and no AC voltage present at the output anymore.
- **Screen 4.39:** This alarm appears after 3 times detecting output short-circuit. Then the UPS and the static bypass are switched off and no AC voltage present at the output anymore.
- **Screen 4.40:** This alarm appears when there is a (\*) DSP Internal Error in the UPS module, for three times shutting down the UPS. The UPS blocks including the bypass, so no AC voltage present at the output anymore.
- **Screen 4.41:** This alarm appears when there is one of the following conditions:
  - ❑ Positive DC bus voltage over 275V.
  - ❑ Positive DC bus voltage less than 200V.
  - ❑ Negative DC bus voltage over -275V (absolute value).
- **Screen 4.42:** This alarm appears when the UPS is blocked for any reason. This condition blocks also the rectifier.
- **Screen 4.43:** After 3 times shutting down the rectifier for desaturation and retry, this alarm will appear indicating rectifier blocked.
- **Screen 4.44:** If an error in the initial rectifier ramp is detected during the PFC start up, this alarm will appear blocking also the rectifier.
- **Screen 4.45:** There is a command from the microprocessor to the DSP, with no response from the rectifier module of the DSP. The rectifier will block.
- **Screen 4.46:** After 4 times shutting down the rectifier because of (\*) DSP Internal Error in the rectifier module, this alarm will appear indicating rectifier blocked.
- **Screen 4.47:** During the start up there is an input contactor test. If this test ends unsuccessfully the rectifier will be blocked.
- **Screen 4.48:** If the output voltage ramp doesn't work properly during the inverter start up the inverter will be blocked.
- **Screen 4.49:** This alarm appears when there is an offset voltage higher than 8V, in any phase of the inverter output voltage phase to neutral. Then the inverter will be blocked.
- **Screen 4.50:** This alarm appears when the UPS is blocked for any reason. This condition blocks also the inverter.
- **Screen 4.51:** After 3 times shutting down the inverter for desaturation and retry, this alarm will appear indicating inverter blocked.
- **Screen 4.52:** There is a command from the microprocessor to the DSP, with no response from the inverter module of the DSP. The inverter will block.
- **Screen 4.53:** After 5 times shutting down the inverter because of (\*) DSP Internal Error in the inverter module, this alarm will appear indicating inverter blocked.
- **Screen 4.54:** This alarm appears when the rectifier is blocked for some reasons that can also blocks the UPS.
- **Screen 4.55:** The alarm appears when the DSP doesn't response to the microprocessor during the initial procedure before the start up.
- **Screen 4.56:** There is a command from the microprocessor to the DSP, with no response from the UPS module of DSP. The UPS will block.
- **Screen 4.57:** This alarm appears when the inverter is blocked for some reasons that can also blocks the UPS.
- **Screen 4.58:** There is an internal error in the communication channel between microprocessor and DSP. This condition blocks the UPS.
- **Screen 4.59:** This alarm appears when, in a parallel system, one UPS goes to battery mode. After some period of time, the UPS will shut down.
- **Screen 4.60:** When an overtemperature is detected by the PFC or inverter temperature sensors, first the inverter will be turned off automatically after 1 minute time (alarm 4.31). If one minute later the overtemperature is still detected, the UPS will be completely blocked (rectifier also shut-down) and the alarm appears.
- **Screen 4.61:** When the rectifier is overloaded, depending on the level of this overload, the inverter will be shut down after some time according to the rectifier overload curve (alarm 4.32). If this overload is still present with the inverter switched off, the UPS will be completely blocked (rectifier also shut-down) after 30", appearing this alarm message.

- **Screen 4.62:** When any IGBT in the inverter side, desaturates the number of times programmed by display (200 by default) the inverter blocks. After two more retries this alarm appears indicating UPS blocked.
- **Screen 4.63:** After 3 times shutting down the UPS because of (\*) DSP Internal Error in the UPS module, this alarm will appear indicating UPS blocked.
- **Screen 4.64:** If there is a blocking condition for the inverter and also a blocking condition for the PFC, this alarm appears blocking also the UPS.

(\*) DSP Internal Error can happen for the following reasons:

- Watch Dog failure.
- Wrong ADC mesures.
- Communication errors between DSP and uprocessor.

### 6.3.6. "DATA LOGGER" level (screen menu 5.0). See Fig. 35.

- **Screen 5.1:** Indicates the inverter runtime from the first unit startup. This counter accumulates the total inverter running time frOm the beginning and it's not possible to reset it.
- **Screen 5.2:** This screen indicates that the datta logger is empty. This happen only if authorised personnel resets this file. If the buffer is not empty, the following screen will inform about the data logger registers.  
Using the (↵), (↶) keys, you can move throught the different registers of this historic file. The data logger file can save up to 100 historic registers.  
Using the (→), (←) you can see the three different screens per register with the information described below.
- **Screen 5.3:** In this screen appears the same information described above in the alarm screens except the three first characters where there is a register counter from 00) to 99).

• **Screen 5.4:** This screen is divided in two rows. In the first row there is information about time and date of alarm activation:

- hh: hour of alarm activation
- mm: minutes of alarm activation
- ss: seconds of alarm activation
- dd: day of alarm activation
- mm: month of alarm activation
- yy: year of alarm activation

In the secon row there is information about time and date of deleted alarm.

- hh: hour of deleted alarm
- mm: minutes of deleted alarm
- ss: seconds of deleted alarm
- dd: day of deleted alarm
- mm: month of deleted alarm
- yy: year of deleted alarm

• **Screen 5.5:** This is a screen for technical service, to know the state of the different parts of the UPS at the moment the registered alarm was activated.

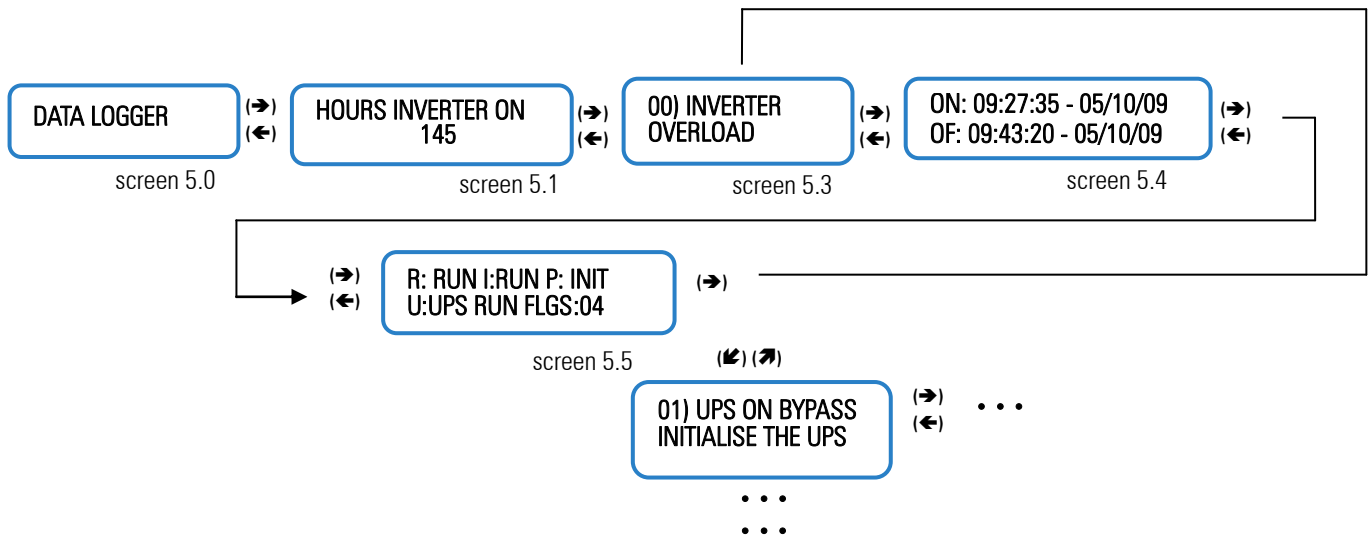

When pressing key (ESC) from any screen of any submenu, we go back to main screen (Screen 0.0),

Fig.35. Screen 5.0 «Data logger» and its submenus.

**6.3.7. "CONFIGURATION" level (screen menu 6.0). See Fig. 36.**



**Fig.36.** Screen 6.0 «Configuration».

At this level an authorized password will be required to modify some advanced parameters.

**6.3.8. Rated values screens (screen menu 7.0). See Fig. 37.**

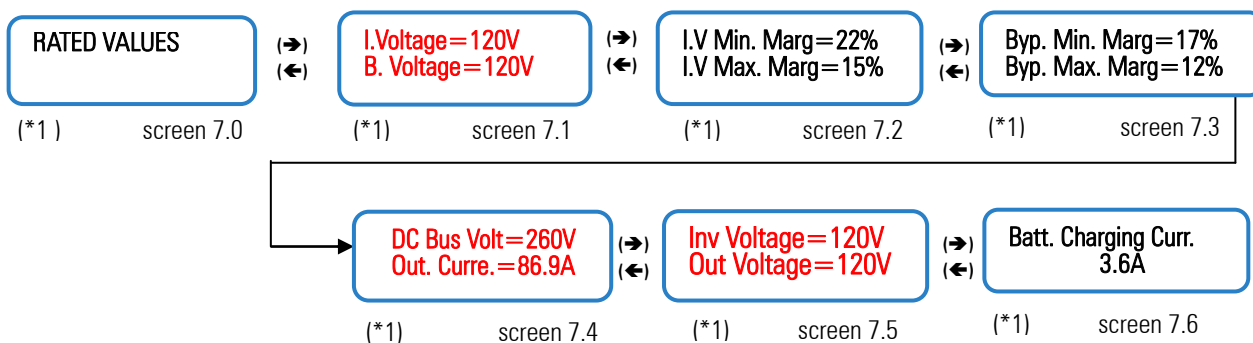

**Fig.37.** Screen 7.0 «Rated values» and its submenus.

To modify the rated values on the screens of this submenu, it is necessary to introduce the «Password» on the previous screen 6.0, otherwise they only will be able to be visualized.

- **Screen 7.1:** This screen shows the Rated Input Rectifier Voltage and Rated Input Bypass Voltage.
- **Screen 7.2:** This screen shows the Input Rectifier Voltage Upper Margin and Input Rectifier Voltage Lower Margin.
- **Screen 7.3:** This screen shows the Input Bypass Voltage Upper Margin and Input Bypass Voltage Lower Margin.
- **Screen 7.4:** This screen shows the Rated DC Bus Voltage and the Rated Output Current.
- **Screen 7.5:** This screen shows the Rated Inverter Voltage and Rated Output Voltage.
- **Screen 7.6:** This screen shows the Rated Battery Charging Current.

## 7. Maintenance, warranty and service.

### 7.1. Basic maintenance guide.

Batteries, fans and capacitors must be replaced at the end of their useful lifetime.

 Inside the UPS there are dangerous voltages and metallic parts at very high temperatures, although the UPS is shutdown. The direct contact can cause electrocutions and burns. All the operating, less the battery fuse replacing, must be done by authorised technical staff.

 Some internal parts of the UPS (terminals, EMC filters and measurement circuits) are still under voltage during the maintenance bypass operating. To cancel all the voltages, the circuit breakers of mains and bypass of the panel that feeds the UPS and the fuse holders of the external battery cabinet have to be turned «OFF» / «0». The internal batteries must also be isolated from the system.

#### 7.1.1. Battery fuses.

Turning on the battery switch or fuse holder according to power of equipment («ON» or «I» position) before alarm message «BATT. SWITCH OPEN, SWITCH IT ON» is displayed in the LCD panel can blow the battery fuses or switch.

 The battery fuses can only be replaced by ultrafast models type Gould aR 660V (14x51 or 22x58 mm, depending on the unit model) of the same dimensions and rating.

#### 7.1.2. Batteries.

The useful lifetime of the batteries depends on the ambient temperature and other factors like the quantity of charging and discharging cycles and the deep discharges done.

The average lifetime is between 3 and 7 years if the ambient temperature is between 10 and 20°C. To have more information of its status, activate the battery test.

 Risk of fire and/or explosion exists if a wrong quantity or type of batteries is used.  
Do not dispose the batteries to the fire: they can explode. Do not open and mutilate the batteries: the dumped electrolyte is dangerous for the skin and eyes. It can be toxic.

#### 7.1.3. Fans.

The useful lifetime of the used fans to cool the power circuits depends on the use and environment conditions. It is recommended their preventive replacement by authorised technical staff.

#### 7.1.4. Capacitors.

The useful lifetime of the DC bus capacitors and those ones used in the input and output filtering depends on the use and the environment conditions. It is recommended their preventive replacement by authorised technical staff.

### 7.2. Warranty conditions.

The limited warranty only applies to those products that you acquire for commercial or industrial use in the normal development of your business.

#### 7.2.1. Covered product.

**Online UPS.**

#### 7.2.2. Out of the scope of supply.

**Our company** is not forced by the warranty if it appreciates that the defect in the product doesn't exist or it was caused by a wrong use, negligence, installation and/or inadequate testing, tentative of repairing or not authorized modification, or any other cause beyond the foreseen use, or by accident, fire, lightnings or other dangers. Neither it will cover, in any case, compensations for damages or injuries.

## 8. ANNEXES.

### 8.1. GENERAL TECHNICAL SPECIFICATIONS.

Nominal power (kVA)	7.5	10	15	20	30	40
<b>Input</b>						
Nominal voltage	Single phase 110 V, 120 V or 130 V. Three phase 3x190 V, 3x208 V or 3x225 V (4 wires: 3 phases + N).					
Input voltage margin	+ 15% / -20%.					
Frequency	50 / 60 Hz $\pm$ 5 %.					
Input current total harmonic distortion	100 % load: THD-i < 1.5 %. 50 % load: THD-i < 2.5 %. 10 % load: THD-i < 6.0 %.		100 % load: THD-i < 1.0 %. 50 % load: THD-i < 2.0 %. 10 % load: THD-i < 5.0 %.			
Current limit	High overload: PFC Limit (discharging batteries).					
Power factor	1.0 (at any load condition).					
<b>Inverter</b>						
Nominal voltage	Single phase 110 V, 120 V or 130 V. Three phase 3x190 V, 3x208 V or 3x225 V (4 wires: 3 phases + N)					
Precision	Stationary: $\pm$ 1 %. Transitory: $\pm$ 2 % (load variations 100-0-100 %).					
Frequency	50 / 60 Hz synchronised $\pm$ 4 %. With mains absent $\pm$ 0.05 %.					
Max. synchronisation speed	$\pm$ 1 Hz/s.					
Wave form	Sine-wave.					
Output voltage total harmonic distortion	Linear load: THD-v < 0.5 %. Ref. non-linear load (EN-62040-3): THD-v < 1.5 %.					
Phase displacement	120 $\pm$ 1 % (balanced load). 120 $\pm$ 2 % (imbalances 50 % of the load).					
Dynamic recovery time	10 ms. at 98 % of the static value.					
Admissible overload	125 % for 10 min., 150 % for 60 s.					
Admissible crest factor	3.4 to 1.		3.2 to 1.		2.8 to 1.	
Admissible power factor	0.7 inductive to 0.7 capacitive.					
Imbalance output voltage with load 100 % unbalanced	< 1 %.					
Current limit	High overload, short-circuit: RMS voltage Limit. High Crest-Factor current: Peak Voltage Limit.					
<b>STATIC BYPASS</b>						
Type	Solid state.					
Voltage	Single phase 110 V, 120 V or 130 V. Three phase 3x190 V, 3x208 V or 3x225 V (4 wires: 3 phases + N)					
Frequency	50 / 60 Hz					
Activation criterion	Microprocessor control.					
Transfer time	Null.					
Admissible overload	400 % for 10 sec.					
Transfer to bypass	Immediate, for overloads above 150 %.					
Retransfer	Automatic after alarm clear.					
<b>MANUAL BYPASS (maintenance)</b>						
Type	Without interruption.					
Voltage	Single phase 110 V, 120 V or 130 V. Three phase 3x190 V, 3x208 V or 3x225 V (4 wires: 3 phases + N)					
Frequency	50 / 60 Hz.					
<b>GENERAL</b>						
Overall efficiency	90,5 %	91,0 %	92,0 %	92,5 %	93,0 %	94,0 %
<b>Dimensions &amp; weight (cabinet ups)</b>						
Depth x Width x Height (mm) / equipped with castors	700 x 450 x 1100 / YES.			805 x 590 x 1320 / YES.		
Weight (no batteries) (kg)	120		190		200	220
Built-in 2x19 batteries 12 V (Ah)	7	9	12	18	-	-
Weight + built-in batteries (kg)	240	260	350	430	-	-
Batteries terminals torque	Depending on batteries manufacture.					

Table .7. Technical specifications.

DIMENSIONS & WEIGHT EXTERNAL BATTERIES CABINET.		
CABINET SIZE	No 1	No 2
Depth x Width x Height (mm) / equipped with castors	700 x 450 x 1100 / SI	980 x 650 x 1320 / NO
Capacity batteries (Ah) - 2x19 batteries 12 V -	26	40
Weight (kg)	380	610
Batteries terminals torque	Depending on batteries manufacture.	

Table.8. External batteries cabinet.

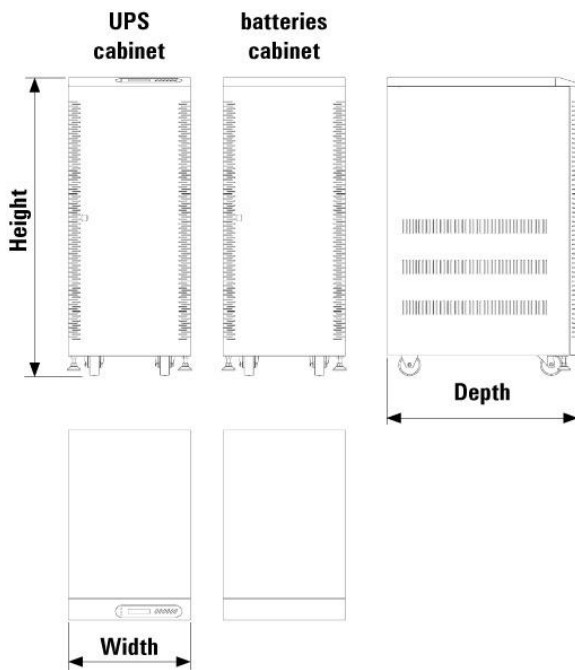

⚠ Some cabinet have no wheels

Fig.38. General technical specifications.

## 8.2. Glossary.

- **AC.-** It is nominated as alternating current to the electrical current in which the magnitude and direction varies in a cyclic way. The most common wave shape of the alternating current is sinewave, because the energy transmission is better. Nevertheless, some applications could need other period wave shapes, like triangular or square.
- **Bypass.-** Manual or automatic, it is the physical junction between the input and the output electric device.
- **DC and AC.-** The direct current is the continuous electron flow through a cable between two points with different potential. Unlike the alternating current, in direct current the electrical loads always flow in the same direction from the highest potential point to the lowest one. Although, usually the direct current is identified with the constant current (for example the one supplied by the battery), it is continuous any current that always maintain the polarity.

- **DSP.-** It is the acronym of Digital Signal Processor. A DSP is a system based on a processor or microprocessor that has instructions in it, a hardware and an optimized software to develop applications where numerical operations are needed with very fast speed. Due to this, it is very useful to process analogical signals in real time: in a system that runs in this way (real time) samples are received, usually coming from an analogical/digital converter(ADC).
- **Power factor.-** It is defined as power factor, p.f., of an alternating current circuit, as the ratio between the active power, P, and the apparent power, S, or as the cosines of the angle that make the current and voltage vectors, designating as  $\cos \phi$ , being  $\phi$  the value of that angle.
- **GND.-** The term ground, as its name states, refers to the potential of the earth surface.
- **IGBT.-** The Insulated Gate Bipolar Transistor is a semiconductor device that is used as a controlled switch in power electronic circuits. This device has the feature of the gate signal of the effect field transistors with the capacity of high current and low voltage saturation of the bipolar transistor, combining an isolated FET gate for the input and a bipolar transistor as switch in a single device. The triggering circuit of the IGBT is as the MOSFET one, while the driving features are like the BJT.
- **Interface.-** In electronic, telecommunications and hardware, an interface (electronic) is the port (physical circuit) through which are sent or received signals from a system or subsystems toward others.
- **kVA.-** The voltampere is the unit of the apparent power in electrical current. In direct current is almost equal to the real power but in alternating current can defer depending on the power factor.
- **LCD.-** LCD acronym of Liquid Crystal Display, device invented by Jack Janning, who was employee of NCR. It is an electric system of data presentation based on 2 transparent conductor layers and in the middle a special crystal liquid that have the capacity to orientate the light when trespassing.
- **LED.-** LED acronym of Light Emitting Diode, is a semiconductor device (diode) that emits light almost monochrome with a very narrow spectrum, it means, when it is direct polarized and it is crossed by an electric current. The colour, (wave longitude), depends on the semiconductor material used in its construction, being able to vary from the ultraviolet one, going through the visible spectrum light, to the infrared, receiving these last ones the denomination of IRED (Infra Red Emitting Diode).
- **Circuit breaker.-** A circuit breaker or switch, is a device ready to break the electrical current of a circuit when it overcomes the maximum set values.



- **On-Line mode.**- Regarding to an equipment, it is on line when it is connected to the system, and it is in operation, and usually has its power supply turned on.
- **Inverter.**- An inverter, is a circuit used to convert direct current into alternating current. The function of an inverter is to change an input voltage of direct current into a symmetrical output voltage of alternating current, with the required magnitude and frequency by the user or the designer.
- **Rectifier.**- In electronic, a rectifier is the element or circuit that allows to convert the alternating current into direct current. This is done by rectifier diodes, which can be solid state semiconductors, vacuum or gassy valves as the mercury vapour. Depending on the features of the alternating current power supply used, it is classified as single phase, when they are fed by a single phase electrical mains, or three phase when they are fed by the three phases. Depending on the rectification type, they can be half wave, when only one of the current semi-cycles is used, or full wave, where both semi-cycles are used.
- **Relay.**- The relay(in French relais, relief) is an electromechanical device that works as a switch controlled by an electric circuit where, through an electromagnet, a set of contacts are moved and



### 8.3 Safety Instructions

#### 1.- TO PROVIDE FOR.

- These "Safety Instructions" are associated to the "Operating Manual" regarding the equipment you have purchased .Before proceeding with the installation or the starting up, check that you have both information, if not ask for them. Compliance with the "Safety Instructions" is obligatory, observance of this being legally the user's responsibility. Read them carefully and follow the steps mentioned by the established order and keep them for future consulting which might arise. The local electrical standards and different restrictions of the end user city may invalidate some of the recommendations given in the manuals. In case of discrepancies, the user must comply with the pertinent local standards. It is possible to come across equipment where the distribution of he connecting terminals and/or commands do not line up with the manual's illustrations. However, the simplicity of the operation together with the correct labelling, permits the easy understanding in an intuitive way.
- It is strictly forbidden to reproduce or to release these information without the written permit from our company.
- Do not install the machine in a corrosive or dusty atmosphere, and never out of doors.
- Do not obstruct the ventilation grilles nor introduce objects through these or other orifices. Leave a minimum free space of 25 cm. around the machine for ventilation and air circulation.
- The location must be spacious, airy, away from heat sources and of easy access. In addition to the ventilation space indicated above, there must be an area of 75 cm. free all round the machinery for possible actions by the After Sales Service (A.S.S.), so that if this involves moving the machine the connecting cables will have the necessary space.

- Do not place materials on top of the machine or objects which would obstruct a correct visualisation of the synoptic reading.

#### 2.- GENERAL SAFETY INSTRUCTIONS.

- All equipment connections including those of the control, should be done without the presence of the mains supply and with the switches turned off, position «0», «Off»,  or  respectively.
- Special attention should be given to the labelling on the equipment warning about the «Risk of electric shock» and indicators like (). Hazardous live parts inside the equipment, do not remove the cover. Reserve servicing to qualified service personnel. For maintenance or repair service, contact your nearest our company After Sales Service (A.S.S.).
- It is compulsory to connect the protection earth, making sure that this is done before powering up the input to the equipment.

For small equipment (input power cord provided with plug), the user should make sure that the wall outlet's voltage corresponds to the type delivered, properly grounded and connected to the local protection earth. For equipment fitted with terminals, the licensed wirer should connect the earth wire to the terminal identified as (.

- The installation of hard wired equipment should be done by personnel qualified in electrical low voltage installations.
- The cross section of the power supply and output cables to the loads should be determined according to the rated current given on the equipment's specifications plate and complying with the Local Low Voltage Electro technical Regulations.
- The power supply cables to the equipment as well as to the loads, interfaces, etc. should be fixed to non movable parts as otherwise they will be exposed to being pulled.
- Please have in mind that if the equipment incorporates a Bypass with mains power available the same will supply output voltage even if the equipment is not turned on. Place warning notices and /or emergency switches is so requested by the safety Regulations of your specific installation.
- The voltage stabilisers and line conditioners should be considered as transformers or distribution lines from the point of view of the installation and of the electrical safety. These equipment are «transparent» to the input voltage.
- The Neutral input of the three phase equipment should be necessarily connected to the terminal foreseen for this purpose.
- On the three phase voltage stabiliser and line conditioners with independent phase regulation existing unbalanced voltage from the three phase input supply on the loads, the phase to phase voltage at the output may not be the same, however the phase to neutral regulation will be kept.

- The line conditioners (voltage stabilisers fitted with galvanic isolation transformer) can be connected with the desired neutral condition. For the isolated neutral condition, the wire bridge going from one output terminal (neutral) to the ground terminal can be suppressed.

- The servo-motor voltage stabilisers and line conditioner incorporate mechanical elements (gearing, dented belts,...) Do not manipulate inside the equipment as the motion during the regulation can originate personal injuries.

- Devices mounted on CHASSIS or RACKS are foreseen for the installation on predetermined assembly unit to be done by professionals.
  - Your installation should be projected and carried out by qualified personnel, who will be responsible of applying the safety and EMC legislation and standards regulating the specific installation where the product will be destined.
  - CHASSIS mounted equipment have neither enveloping protection nor connecting terminals.
  - RACK mounted equipment have no connecting terminal protection.

### 3. - SAFETY INTERACTIONS FOR BATTERY EQUIPPED PRODUCTS.

- The UPS, the SPS and the FAC are continuous supply equipment. If the mains supply fails while the equipment is operating, the output lines will continue supplying output voltage depending on the autonomy provided by the battery.

- Generally the batteries are delivered fitted already in one only cabinet except on determined occasions where due to varied reasons are delivered inside a separate enclosure.

- For proper operation the battery cabinet must be located beside the machine.

- The battery supply can involve the risk of electric shock and can produce high short circuit current. Observe the following preventive measures before manipulating any terminal block identified in the labelling as «Battery».

- Disconnect the corresponding protection elements.

- When connecting a battery cabinet with the equipment respect the cable's polarity and colour (red-positive; black-negative) indicated in the manual and in the corresponding labelling.

- Wear rubber gloves and shoes.

- Use tools with insulated handles.

- Removes watches, rings or other metal objects.

- Do not place metal tools or objects on the batteries.

- Never manipulate with your hands or through conducting objects, do not short the battery terminal block or the battery enclosure.

- To prevent the total battery discharged and as a safety measure after an extended power failure, as well as at the end of the daily work, you should proceed to turn off the loads and later the equipment following the operativity given in the «Operating Manual».

- For extended periods of disconnection connect the equipment every month for at least 10 hours to charge the battery, to avoid the irreversible deterioration of same. In case of storing the equipment, place it in a cool and dry location, never outdoors.

- For installation with supplementary machines or an independent Bypass line, only a single differential of 300 - 500 mA will be placed in common for both lines, at the head of the installation.

### 4. - SAFETY INSTRUCTIONS REGARDING THE BATTERIES.

- Never short the battery terminals as it involves a high risk. It involves the detriment of the equipment and of the equipment and of the battery.

- Avoid mechanical efforts and impacts.

- Do not open or mutilate the battery. Released electrolyte is harmful to the skin and eyes.

- Do not dispose of a battery in a fire. The battery may explode.

- In case of contact of the acid with parts of the body, wash immediately with plenty water and call urgently the nearest medical service.

- Battery involve a serious risk for the health and for the environment. Their disposal should be done according to the existing laws.